

■ **INSTAGRAM**  
FOLLOW US: @LINE\_HAREKAT

**P R O D U C T**  
**C A T A L O G**

---

**LHC**  
LINE HAREKAT Co.

**L I N E**  
**H A R E K A T**

**EVERYTHING YOU NEED TO KNOW**

**مرکز فروش قطعات CNC  
و اتوماسیون صنعتی**

**OUR WEBSITE:**  
**WWW.LINE-HAREKAT.IR**



# ALS R Types Clamp Type

■ALS-014 to 030

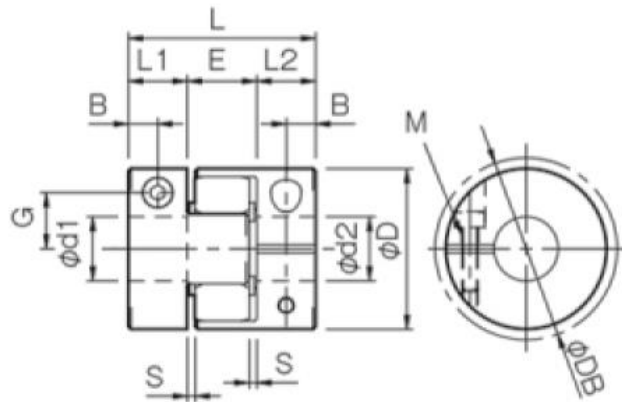

■ALS-040

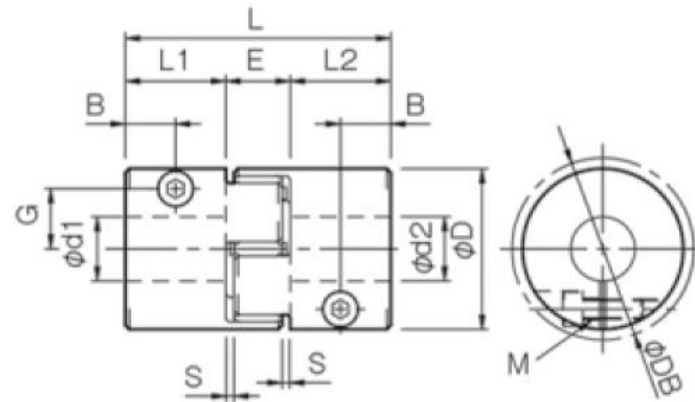

■ALS-055 to 080

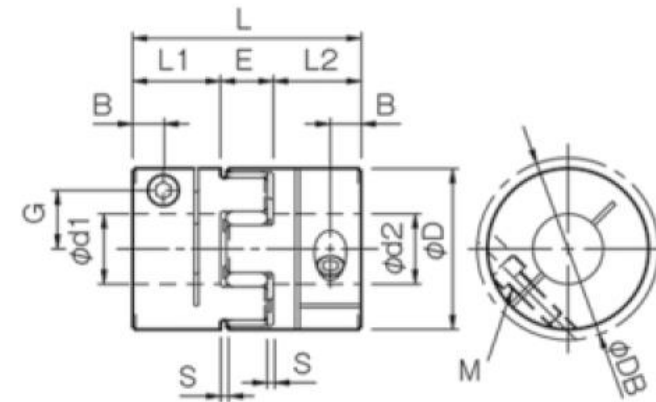

### General Specifications

Model	Misalignment			Max rotation speed (min <sup>-1</sup> )	Static torsional stiffness (N-m/rad)	Radial stiffness (N/mm)	Moment of inertia (Kg-m <sup>2</sup> )	Mass (Kg)
	Parallel (mm)	Angular (°)	Axial (mm)					
ALS-014-R	0.10	1	0 ~ +0.6	10000	21	380	1.98 x 10 <sup>-7</sup>	0.007
ALS-020-R	0.10	1	0 ~ +0.8	10000	43	400	1.09 x 10 <sup>-6</sup>	0.019
ALS-030-R	0.10	1	0 ~ +1.0	10000	136	650	6.19 x 10 <sup>-6</sup>	0.045
ALS-040-R	0.10	1	0 ~ +1.2	10000	1550	1700	4.01 x 10 <sup>-5</sup>	0.16
ALS-055-R	0.10	1	0 ~ +1.4	7000	2000	1350	1.63 x 10 <sup>-4</sup>	0.34
ALS-065-R	0.10	1	0 ~ +1.5	5900	3100	1400	3.69 x 10 <sup>-4</sup>	0.54
ALS-080-R	0.10	1	0 ~ +1.8	4800	6000	1710	1.04 x 10 <sup>-3</sup>	1.00

- \* Axial displacement is not allowed in the negative direction.
- \* Max. rotation speed does not take into account dynamic balance.
- \* Stiffness values given are from measurements taken at 20°C
- \* The moment of inertia and mass are measured for the maximum bore diameter.

### General Specifications

Model	min.		D	DB	L	L1-L2	E	S	B	G	M	Tightening Torque (N-m)
ALS-014-R	0.10	0.10	14	16.1	22	7	8	1	3.5	4.8	1 - M2	0.4
ALS-020-R	0.10	0.10	20	20	30	10	10	1	5	6.5	1 - M2.5	1
ALS-030-R	0.10	0.10	30	30	35	11	13	1.5	5.5	10.5	1 - M3	1.5
ALS-040-R	0.10	0.10	40	43.2	66	25	16	2	12.5	15	1 - M5	7
ALS-055-R	0.10	0.10	55	55	78	30	18	2	10.5	20	1 - M6	14
ALS-065-R	0.10	0.10	65	69.8	90	35	20	2.5	11.5	24.5	1 - M8	30
ALS-080-R	0.10	0.10	80	80	114	45	24	3	11.5	30	1 - M8	30

### General Specifications

Model	Standard bore diameter d1, d2 (mm) and rated transmission torque (n-m)																						
	3	4	5	6	6.35	7	8	10	11	12	14	15	16	18	19	20	22	24	25	28	30	35	42
ALS-014-R	0.31	0.42	0.54	0.65																			
ALS-020-R		1.2	1.6	2.1	2.2	2.6	3.0																
ALS-030-R				2.0	2.2		3.4	4.7	5.4	6.0	7.4												
ALS-040-R							8	16		23	31	34	34		34								
ALS-055-R												38	41	48	51	54	61	67	71	80			
ALS-065-R																61	68	75	79	89	96	114	
ALS-080-R																				108	121	151	194





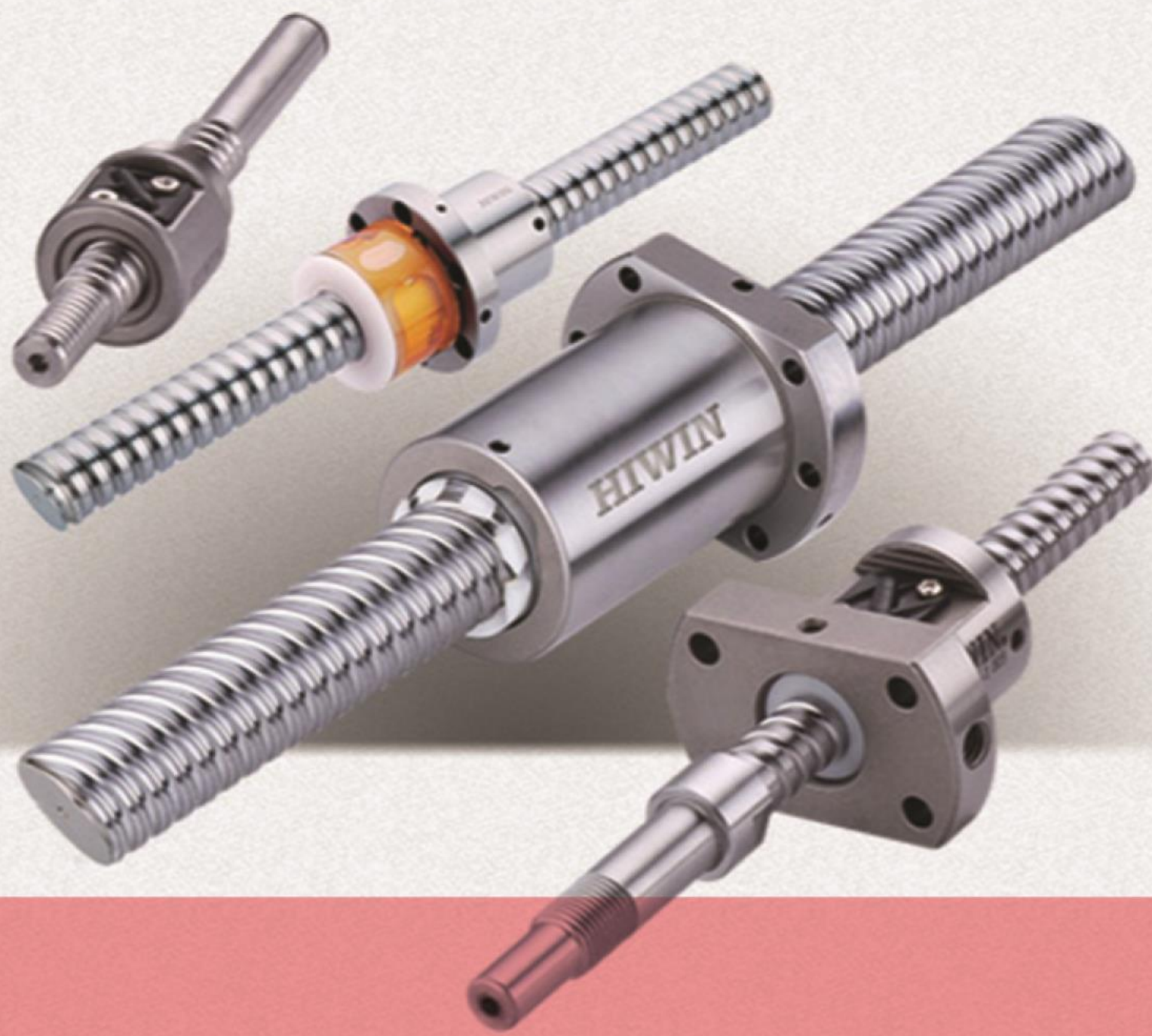

# BALLSCREWS ►

Ballscrews consist of a screw spindle and a nut integrated with rolling elements that cycle through a return mechanism

## General Type Of Rolled Ballscrews

Model	Size		Ball Dia	Circuits	Dynamic Load C [kgf]	Static Load C [kgf]	W	Hxt	F	L	B	C	K	T	A	M [max]	Z
	Nominal Dia.	Lead															
14-4B1	14	4	2.381	2.5x1	376	682	34	M4x7	13	35	26	22	6.5	6	M6	30	6
14-4C1	14	4	2.381	3.5x1	498	943	34	M4x7	13	35	26	22	6.5	6	M6	30	6
14-5B1	14	5	3.175	2.5x1	636	1095	34	M4x7	13	35	26	22	6.5	6	M6	31	6
16-5B1	16	5	3.175	2.5x1	679	1226	42	M5x8	16	36	32	22	7	21.5	M6	36	6
20-5B1	20	5	3.175	2.5x1	745	1526	48	M6x10	17	35	35	22	6.5	9	M6	39	5
20-10B1	20	10	4.763	2.5x1	1280	2314	48	M6x10	18	58	35	35	11.5	9	M6	46	10
25-5B1	25	5	3.175	2.5x1	845	1987	60	M8x12	20	35	40	22	6.5	9.5	M6	45	7
25-10B2	25	10	6.350	2.5x2	3816	7968	60	M8x12	23	94	40	60	17	10	M6	54	10
28-6B1	28	6	3.969	2.5x1	1203	2796	60	M8x12	22	42	40	18	12	10	M6	50	8
28-6B2	28	6	3.969	2.5x2	2184	5592	60	M8x12	22	67	40	40	13.5	10	M6	50	8
32-10B1	32	10	6.350	2.5x1	2413	5172	70	M8x12	26	64	50	45	9.5	12	M6	62	10
32-10B2	32	10	6.350	2.5x2	4379	10345	70	M8x12	26	94	50	60	17	12	M6	67	10
36-10B2	36	10	6.350	2.5x2	4592	11403	86	M10x16	29	96	60	60	18	17	M6	67	11
45-12B2	45	12	7.144	2.5x2	5963	16110	100	M12x20	36	115	75	75	20	20.5	M6	80	13

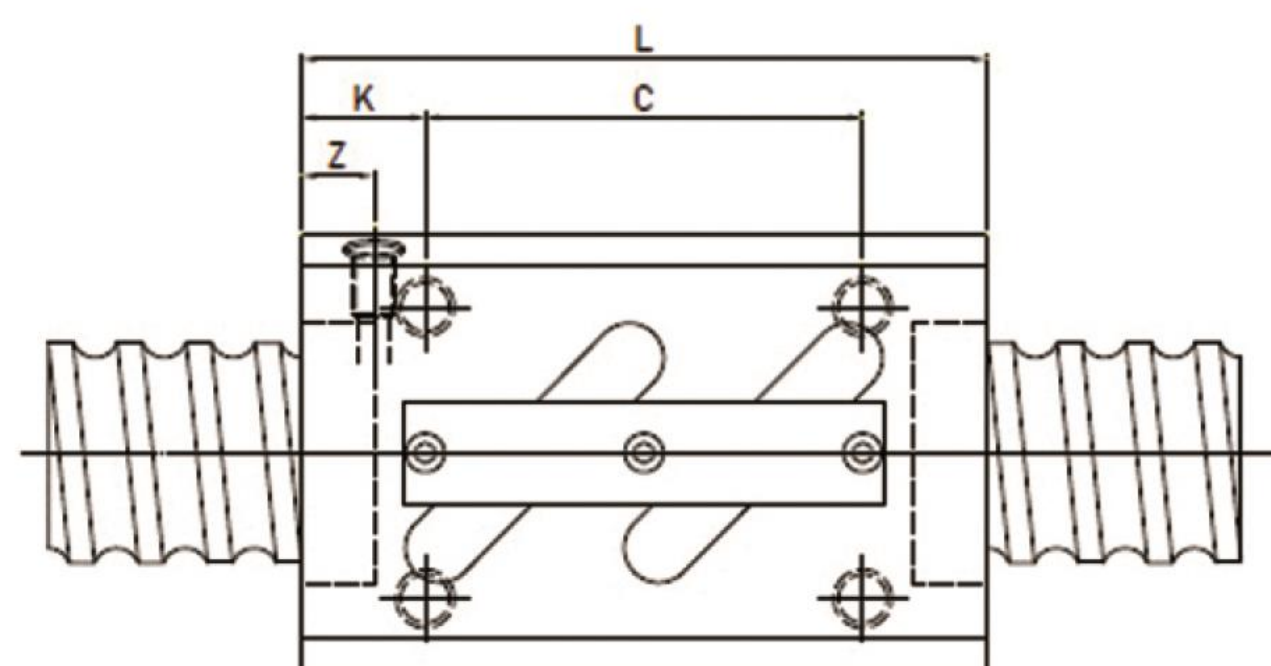
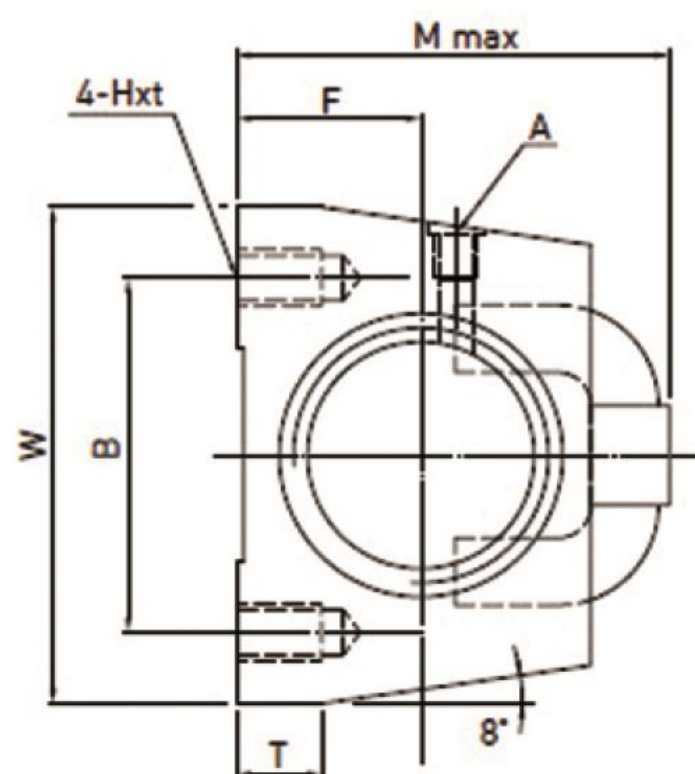



## DIN Single Nuts FSC DIN [DIN 69051 part 5]

## DIN Single Nuts FSI DIN [DIN 69051 part 5]

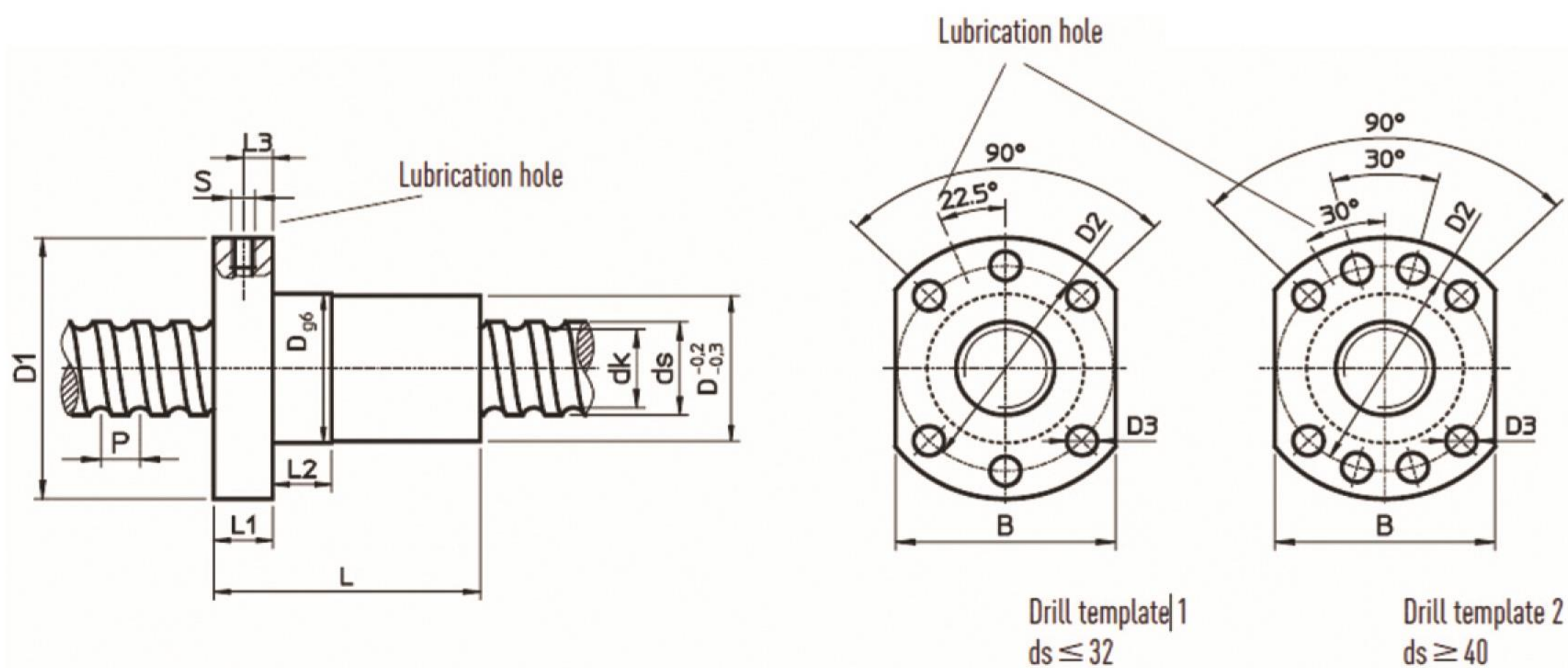

Article number	ds	p	D g6	D1	D2	D3	Drill template	L	L1	L2	L3	S	B	dk	Dyn.load C <sub>dyn</sub> [N]	Stat load C <sub>0</sub> [N]	Axial play Max.[mm]	Mass [kg/pc]
R16-05T3-FSIDIN	16	5	28	48	38	5.5	5.5	40	10	10	5	M6	40	12.8	7320	12470	0.04	0.17
R16-10T3-FSIDIN	16	10	28	48	38	5.5	5.5	60	10	10	5	M6	40	12.8	6230	11000	0.04	0.25
R20-05T4-FSIDIN	20	5	36	58	47	6.6	6.6	52	10	10	5	M6	44	16.9	11560	24000	0.04	0.29
R20-10K3-FSCDIN	20	10	36	58	47	6.6	6.6	48	10	10	5	M6	44	17.3	10000	23500	0.04	0.27
R20-20K2-FSCDIN	20	20	36	58	47	6.6	6.6	57	10	10	5	M6	44	17.0	6800	15300	0.04	0.30
R25-05T4-FSIDIN	25	5	40	62	51	6.6	6.6	52	10	12	5	M6	48	22.3	12400	32960	0.04	0.31
R25-10T3-FSIDIN	25	10	40	62	51	6.6	6.6	65	10	16	5	M6	48	21.2	16500	32700	0.04	0.35
R25-25K2-FSCDIN	25	25	40	62	51	6.6	6.6	70	10	16	5	M6	48	22.3	7500	19300	0.04	0.37
R32-05T6-FSIDIN	32	5	50	80	65	9	9	66	12	12	6	M6	62	29.1	20560	64700	0.04	0.70
R32-10T4-FSIDIN	32	10	50	80	65	9	9	85	12	16	6	M6	62	27.7	38500	65000	0.04	0.82
R32-20K3-FSCDIN	32	20	50	80	65	9	9	88	12	16	7	M6	62	28.7	17000	48500	0.04	0.88
R32-32K2-FSCDIN	32	32	50	80	65	9	9	88	12	12	6	M6	62	28.7	11600	31800	0.04	0.88
R40-05T6-FSIDIN	40	5	63	93	78	9	9	66	14	10	7	M8x1	70	36.7	23360	80300	0.04	1.10
R40-10K4-FSCDIN	38	10	63	93	78	9	9	70	14	16	7	M8x1	70	32.9	45000	123000	0.07	1.10
R40-20K3-FSCDIN	38	20	63	93	78	9	9	88	14	16	7	M8x1	70	32.9	34850	90000	0.07	1.13
R40-40K2-FSCDIN	38	40	63	93	78	9	9	102	14	16	7	M8x1	70	32.9	23000	58400	0.07	1.30
R50-05T6-FSIDIN	50	5	75	110	93	11	11	70	16	10	8	M8x1	85	46.8	25320	104200	0.07	1.44
R50-10K6-FSCDIN	50	10	75	110	93	11	11	90	16	20	8	M8x1	85	44.9	74500	250000	0.07	1.55
R50-20K5-FSCDIN	50	20	75	110	93	11	11	132	18	25	9	M8x1	85	45.5	62000	208000	0.07	2.10
R50-40K3-FSCDIN	50	40	75	110	93	11	11	149	18	45	9	M8x1	85	45.0	39000	123000	0.07	2.50





## Dimension Table of *HQ MOTION* Ball Screws (TYPE) : SFU(DIN 69051 FORM B)

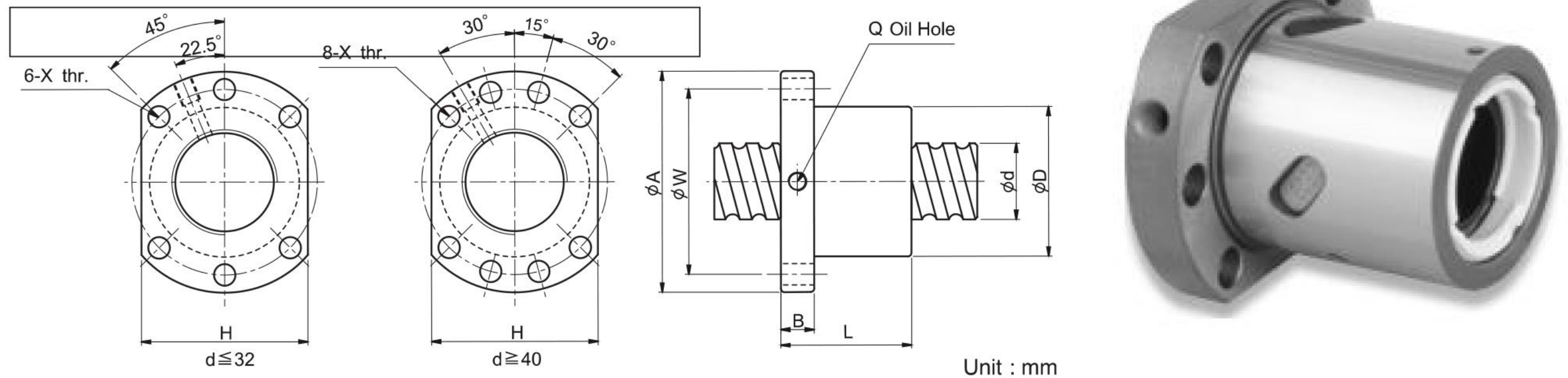

l: Lead      Da: Ball Dia.      n: Number of Circuits      K: Stiffness (Kgf/μm)  
Ca: Basic Dynamic Rating Load (Kgf)      Coa: Basic Static Rating Load(Kgf)

Model No.	Dimensions														
	d	l	Da	D	A	B	L	W	X	H	Q	n	Ca	Coa	K
SFU01204-4	12	4	2.5	24	40	10	40	32	4.5	30		1x4	902	1884	26
★ SFU01604-4		4	2.381	28	48	10	40	38	5.5	40	M6	1x4	973	2406	32
★ SFU01605-4	16	5	3.175	28	48	10	50	38	5.5	40	M6	1x4	1380	3052	32
★ SFU01610-3		10	3.175	28	48	10	57	38	5.5	40	M6	1x3	1103	2401	26
SFU02004-4	20	4	2.381	36	58	10	42	47	6.6	44	M6	1x4	1066	2987	38
★ SFU02005-4		5	3.175	36	58	10	51	47	6.6	44	M6	1x4	1551	3875	39
★ SFU02504-4		4	2.381	40	62	10	42	51	6.6	48	M6	1x4	1180	3795	43
★ SFU02505-4		5	3.175	40	62	10	51	51	6.6	48	M6	1x4	1724	4904	45
SFU02506-4	25	6	3.969	40	62	10	54	51	6.6	48	M6	1x4	2318	6057	47
SFU02508-4		8	4.762	40	62	10	63	51	6.6	48	M6	1x4	2963	7313	49
★ SFU02510-4		10	4.762	40	62	12	85	51	6.6	48	M6	1x4	2954	7295	50
SFU03204-4		4	2.381	50	80	12	44	65	9	62	M6	1x4	1296	4838	51
★ SFU03205-4		5	3.175	50	80	12	52	65	9	62	M6	1x4	1922	6343	54
SFU03206-4	32	6	3.969	50	80	12	57	65	9	62	M6	1x4	2632	7979	57
SFU03208-4		8	4.762	50	80	12	65	65	9	62	M6	1x4	3387	9622	60
★ SFU03210-4		10	6.35	50	80	12	90	65	9	62	M6	1x4	4805	12208	61
★ SFU04005-4		5	3.175	63	93	14	55	78	9	70	M8	1x4	2110	7988	63
SFU04006-4	40	6	3.969	63	93	14	60	78	9	70	M6	1x4	2873	9913	66
SFU04008-4		8	4.762	63	93	14	67	78	9	70	M6	1x4	3712	11947	70
★ SFU04010-4		10	6.35	63	93	14	93	78	9	70	M8	1x4	5399	15500	73
★ SFU05010-4	50	10	6.35	75	110	16	93	93	11	85	M8	1x4	6004	19614	85
★ SFU05020-4		20	7.144	75	110	16	138	93	11	85	M8	1x4	7142	22588	94
SFU06310-4	63	10	6.35	90	125	18	98	108	11	95	M8	1x4	6719	25358	99
SFU06320-4		20	9.525	95	135	20	149	115	13.5	100	M8	1x4	11444	36653	112
★ SFU08010-4	80	10	6.35	105	145	20	98	125	13.5	110	M8	1x4	7346	31953	109
SFU08020-4		20	9.525	125	165	25	154	145	13.5	130	M8	1x4	12911	47747	138
SFU10020-4	100	20	9.525	150	202	30	180	170	17.5	155	M8	1x4	14303	60698	162

Note: with sign ★ can be produced in left helix



## 2-3-12 Dimensions for HIWIN MGN / MGW Series

### (1) MGN-C / MGN-H

MGN 7,  
MGN 9,  
MGN 12,

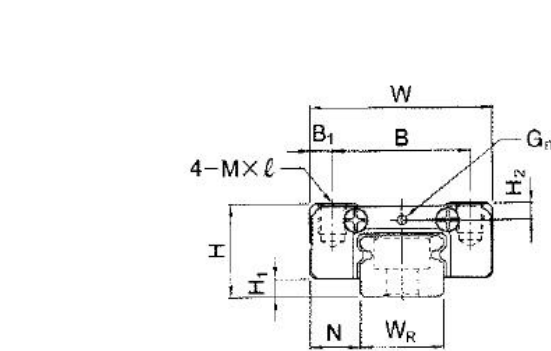

MGN 15

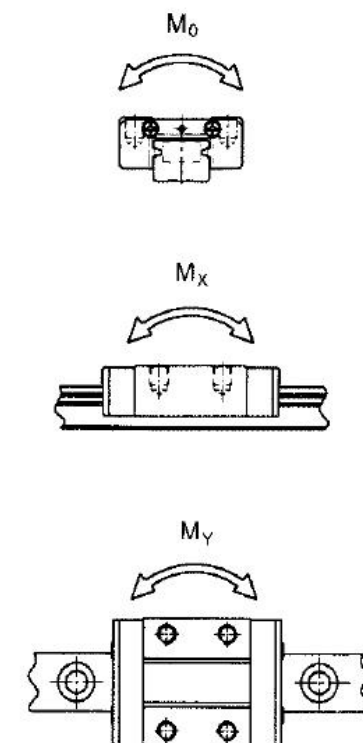
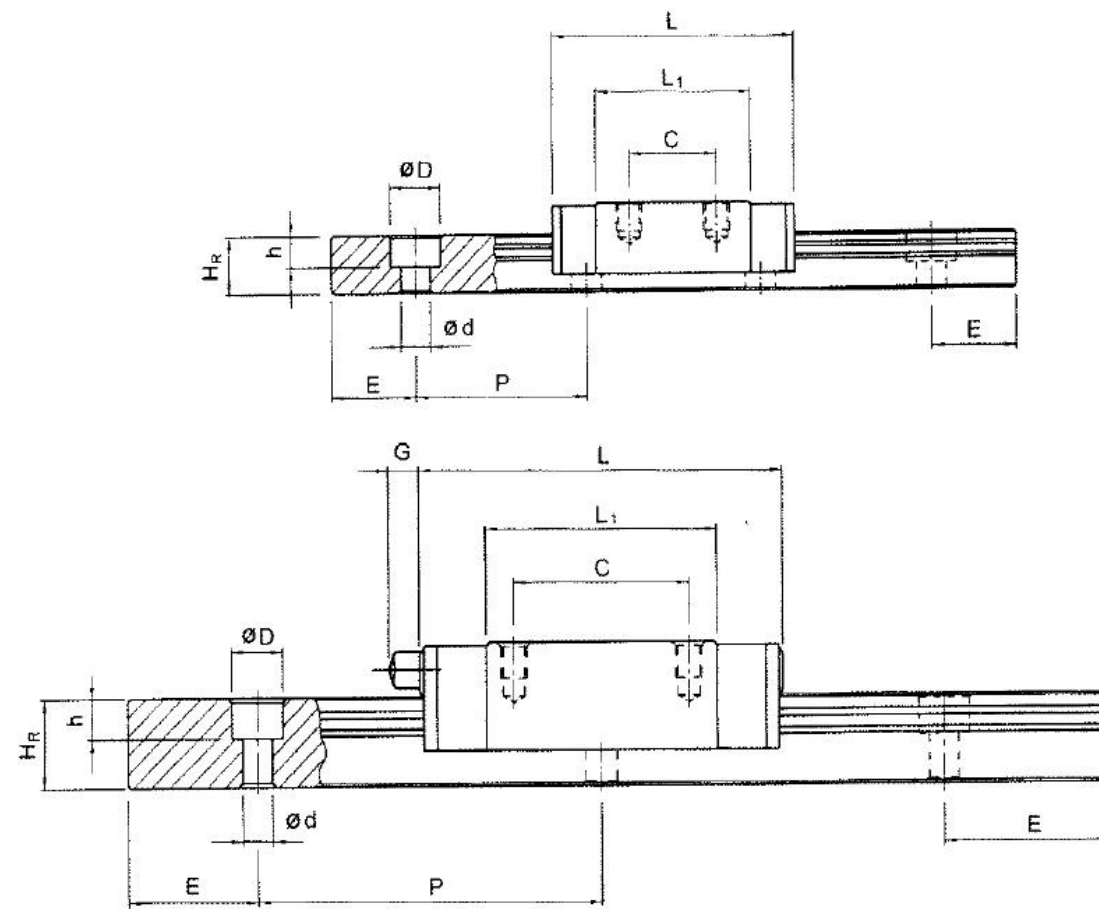
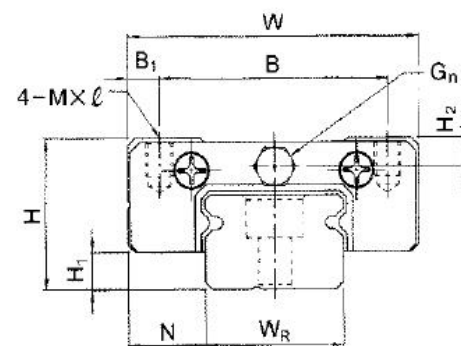

Model No.	Dimensions of Assembly (mm)				Dimensions of Block (mm)								Dimensions of Rail (mm)								Mounting Bolt for Rail (mm)	Basic Dynamic Load Rating (kgf)	Basic Static Load Rating (kgf)	Static Rated Moment (kgf-m)			Weight	
	H	H <sub>1</sub>	N	W	B	B <sub>1</sub>	C	L <sub>1</sub>	L	G	M×l	G <sub>n</sub>	H <sub>2</sub>	W <sub>r</sub>	H <sub>r</sub>	D	h	d	P	E				C	C <sub>0</sub>	M <sub>0</sub>	M <sub>x</sub>	M <sub>y</sub>
MGN7-C	8	1.5	5	17	12	2.5	8	13.5	22.5	-	M2×2.5	□0.8	1.5	7	4.8	4.2	2.3	2.4	15	5	M2×6	100	127	0.48	0.29	0.29	10	0.22
MGN7-H							13	21.8	30.8													140	200	0.78	0.49	0.49	15	
MGN9-C	10	2	5.5	20	15	2.5	10	18.9	28.9	-	M3×3	□0.8	1.8	9	6.5	6	3.5	3.5	20	7.5	M3×8	190	260	1.2	0.75	0.75	16	0.38
MGN9-H							16	29.9	39.9													260	410	2	1.9	1.9	26	
MGN12-C	13	3	7.5	27	20	3.5	15	21.7	34.7	-	M3×3.5	□0.8	2.5	12	8	6	4.5	3.5	25	10	M3×8	290	400	2.6	1.4	1.4	34	0.65
MGN12-H							20	32.4	45.4													380	600	3.9	3.7	3.7	54	
MGN15-C	16	4	8.5	32	25	3.5	20	26.7	42.1	4.5	M3×4	+	3	15	10	6	4.5	3.5	40	15	M3×10	470	570	4.6	2.2	2.2	59	1.06
MGN15-H							25	43.4	58.8													650	930	7.5	5.9	5.9	92	

### (2) MGW-C / MGW-H

MGW 7,  
MGW 9,  
MGW 12,

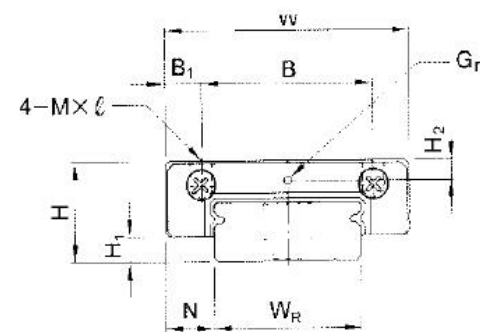

MGW 15,

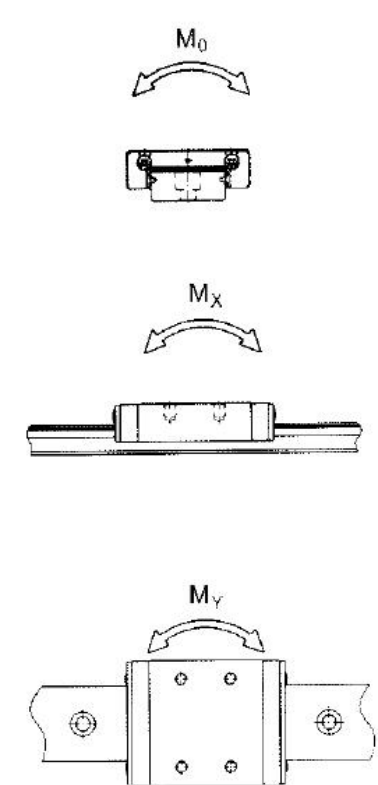
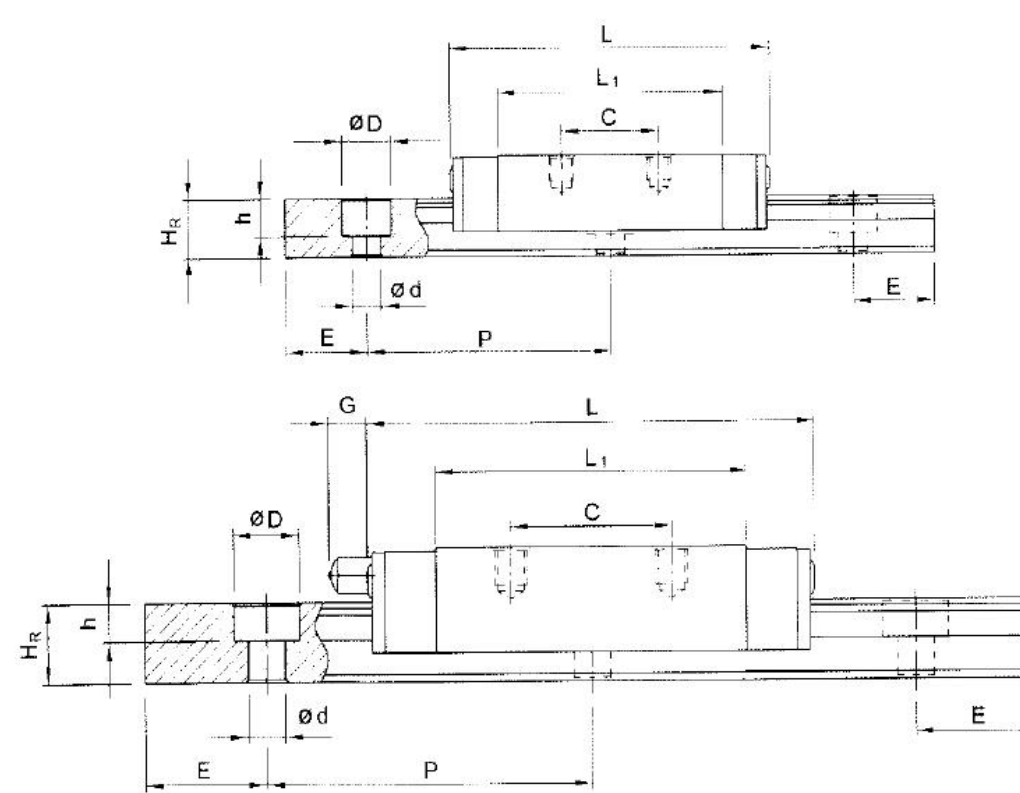
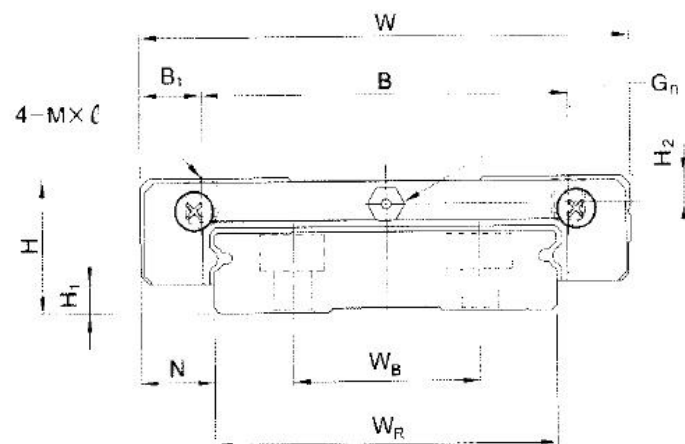

Model No.	Dimensions of Assembly (mm)				Dimensions of Block (mm)								Dimensions of Rail (mm)								Mounting Bolt for Rail (mm)	Dynamic Load Rating (kgf)	Static Load Rating (kgf)	Static Rated Moment (kgf-m)			Weight		
	H	H <sub>1</sub>	N	W	B	B <sub>1</sub>	C	L <sub>1</sub>	L	G	M×l	G <sub>n</sub>	H <sub>2</sub>	W <sub>r</sub>	W <sub>B</sub>	H <sub>r</sub>	D	h	d	P				E	C	C <sub>0</sub>	M <sub>0</sub>	M <sub>x</sub>	M <sub>y</sub>
MGW7-C	9	1.9	5.5	25	19	3	10	21	31.2	-	M3×3	□0.9	1.85	14	-	5.2	6	3.2	3.5	30	10	M3×6	140	210	1.6	0.73	0.73	20	0.51
MGW7-H							19	30.8	41														180	320	2.39	1.58	1.58	29	
MGW9-C	12	2.9	6	30	21	4.5	12	27.5	39.3	-	M3×3	□1.0	2.4	18	-	7	6	4.5	3.5	30	10	M3×8	280	420	4.09	1.93	1.93	40	0.91
MGW9-H							24	38.5	50.7														350	600	5.56	3.47	3.47	57	
MGW12-C	14	3.4	8	40	28	6	15	31.3	46.1	-	M3×3.6	□1.0	2.8	24	-	8.5	8	4.5	4.5	40	15	M4×10	400	570	7.17	2.83	2.83	71	1.49
MGW12-H							28	45.6	60.4														520	840	10.47	5.85	5.85	103	
MGW15-C	16	3.4	9	60	45	7.5	20	38	54.8	5.2	M4×4.2	+	3.2	42	23	9.5	8	4.5	4.5	40	15	M4×10	690	940	20.32	5.78	5.78	143	2.86
MGW15-H							35	57	73.8														910	1410	30.48	12.5	12.5	215	



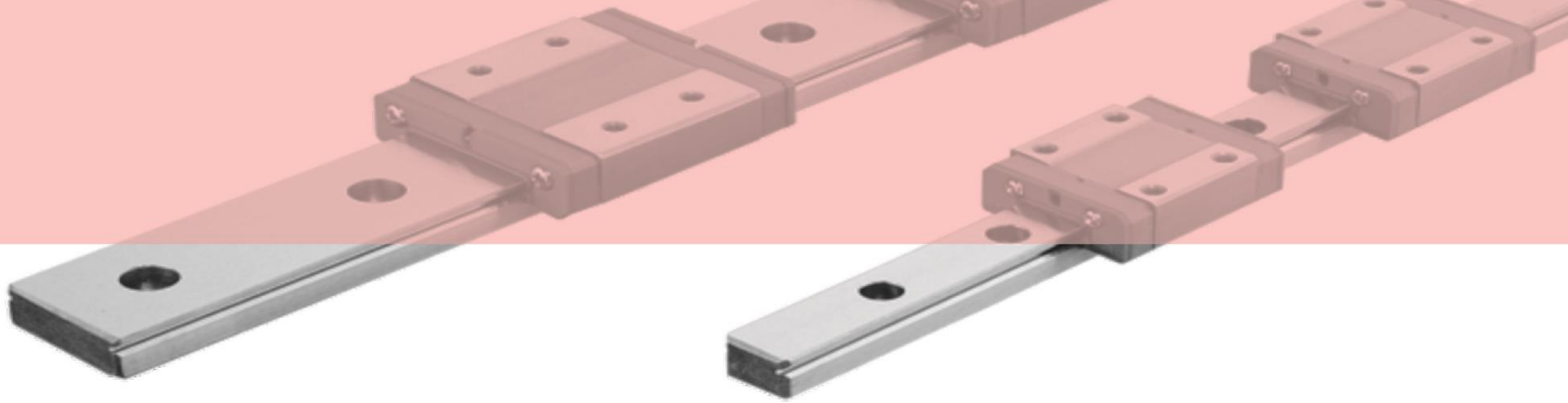

## 2-2-13 Dimensions for HIWIN EG Series

### (1) EGH-SA / EGH-CA

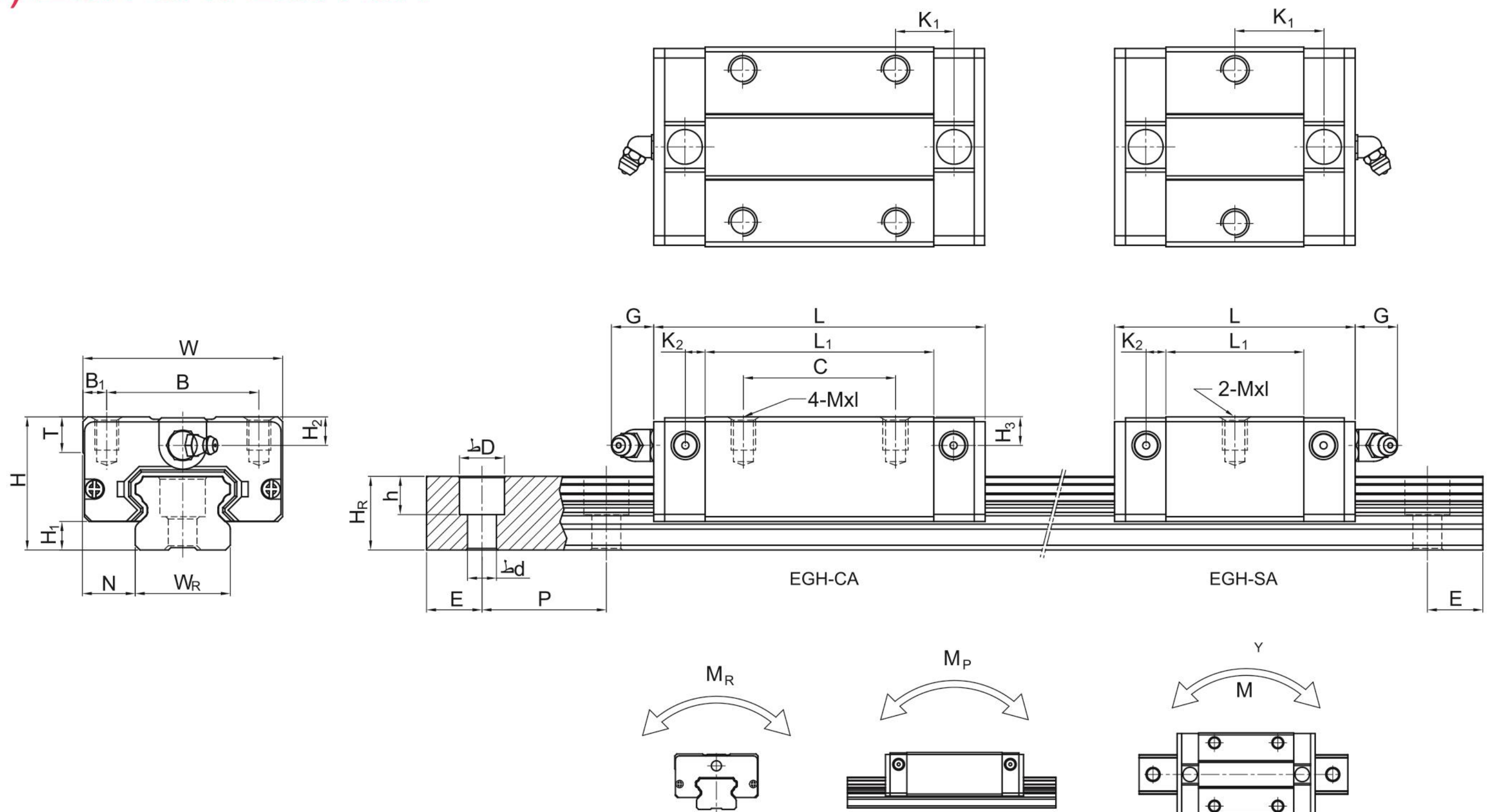

Model No.	Dimensions of Assembly (mm)		Dimensions of Block (mm)														Dimensions of Rail (mm)						Mounting Bolt for Rail (mm)	Basic Dynamic Load Rating C(kN)	Basic Static Load Rating C <sub>0</sub> (kN)	Static Rated Moment			Weight		
	H	H <sub>1</sub>	N	W	B	B <sub>1</sub>	C	L <sub>1</sub>	L	K <sub>1</sub>	K <sub>2</sub>	G	Mxl	T	H <sub>2</sub>	H <sub>3</sub>	W <sub>R</sub>	H <sub>R</sub>	D	h	d	P				E	M <sub>R</sub>	M <sub>P</sub>	M <sub>Y</sub>	Block kg	Rail kg/m
EGH15SA	24	4.5	9.5	34	26	4	-	23.1	40.1	14.8	3.5	5.7	M4x6	6	5.5	6	15	12.5	6	4.5	3.5	60	20	M3x16	5.35	9.40	0.08	0.04	0.04	0.09	1.25
EGH15CA							26	39.8	56.8	10.15															7.83	16.19	0.13	0.10	0.10	0.15	
EGH20SA	28	6	11	42	32	5	-	29	50	18.75	4.15	12	M5x7	7.5	6	6	20	15.5	9.5	8.5	6	60	20	M5x16	7.23	12.74	0.13	0.06	0.06	0.15	2.08
EGH20CA							32	48.1	69.1	12.3															10.31	21.13	0.22	0.16	0.16	0.24	
EGH25SA	33	7	12.5	48	35	6.5	-	35.5	59.1	21.9	4.55	12	M6x9	8	8	8	23	18	11	9	7	60	20	M6x20	11.40	19.50	0.23	0.12	0.12	0.25	2.67
EGH25CA							35	59	82.6	16.15															16.27	32.40	0.38	0.32	0.32	0.41	
EGH30SA	42	10	16	60	40	10	-	41.5	69.5	26.75	6	12	M8x12	9	8	9	28	23	11	9	7	80	20	M6x25	16.42	28.10	0.40	0.21	0.21	0.45	4.35
EGH30CA							40	70.1	98.1	21.05															23.70	47.46	0.68	0.55	0.55	0.76	
EGH35SA	48	11	18	70	50	10	-	45	75	28.5	7	12	M8x12	10	8.5	8.5	34	27.5	14	12	9	80	20	M8x25	22.66	37.38	0.56	0.31	0.31	0.66	6.14
EGH35CA							50	78	108	20															33.35	64.84	0.98	0.69	0.69	1.13	



Model No.	Dimensions Of Assembly (mm)			Dimensions Of Block (mm)													Dimensions Of Rail (mm)							Mounting Bolt For Rail (mm)	Basic Dynamic Load Rating C(kN)	Basic Static Load Rating C <sub>0</sub> (kN)	Static Rated Moment			Weight Block Kg	Weight Rail Kg/m
	H	H <sub>1</sub>	N	W	B	B <sub>1</sub>	C	L <sub>1</sub>	L	K <sub>1</sub>	K <sub>2</sub>	G	MxL	T	H <sub>2</sub>	H <sub>3</sub>	W <sub>R</sub>	H <sub>R</sub>	D	h	d	P	E				M <sub>R</sub>	M <sub>P</sub>	M <sub>Y</sub>		
HGH15CA	28	4.3	9.5	34	26	4	26	39.4	61.4	10	4.85	5.3	M4x5	6	7.95	7.7	15	15	7.5	5.3	4.5	60	20	M4x16	11.38	16.97	0.12	0.10	0.10	0.18	1.45
HGH20CA	30	4.6	12	44	32	6	36	50.5	77.5	12.25	6	12	M5x6	8	6	6	20	17.5	9.5	8.5	6	60	20	M5x16	17.75	27.76	0.27	0.20	0.20	0.30	2.21
HGH20HA	30	4.6	12	44	32	6	50	65.2	92.2	12.6	6	12	M5x6	8	6	6	20	17.5	9.5	8.5	6	60	20	M5x16	21.18	35.90	0.35	0.35	0.35	0.39	2.21
HGH25CA	40	5.5	12.5	48	35	6.5	35	58	84	15.7	6	12	M6x8	8	10	9	23	22	11	9	7	60	20	M6x20	26.48	36.49	0.42	0.33	0.33	0.51	3.21
HGH25HA	40	5.5	12.5	48	35	6.5	50	78.6	104.6	18.5	6	12	M6x8	8	10	9	23	22	11	9	7	60	20	M6x20	32.75	49.44	0.56	0.57	0.57	0.69	3.21
HGH30CA	45	6	16	60	40	10	40	70	97.4	20.25	6	12	M8x10	8.5	9.5	13.8	28	26	14	12	9	80	20	M8x25	38.74	52.19	0.66	0.53	0.53	0.88	4.47
HGH30HA	45	6	16	60	40	10	60	93	120.4	21.75	6	12	M8x10	8.5	9.5	13.8	28	26	14	12	9	80	20	M8x25	47.27	69.16	0.88	0.92	0.92	1.16	4.47
HGH35CA	55	7.5	18	70	50	10	50	80	112.4	20.6	7	12	M8x12	10.2	16	19.6	34	29	14	12	9	80	20	M8x25	49.52	69.16	1.16	0.81	0.81	1.45	6.30
HGH35HA	55	7.5	18	70	50	10	72	105.8	138.2	22.5	7	12	M8x12	10.2	16	19.6	34	29	14	12	9	80	20	M8x25	60.21	91.63	1.54	1.40	1.40	1.92	6.30
HGH45CA	70	9.5	20.5	86	60	13	60	97	139.4	23	10	12.9	M10x17	16	18.5	30.5	45	38	20	17	14	105	22.5	M12x35	77.57	102.71	1.98	1.55	1.55	2.73	10.41
HGH45HA	70	9.5	20.5	86	60	13	80	128.8	171.2	28.9	10	12.9	M10x17	16	18.5	30.5	45	38	20	17	14	105	22.5	M12x35	94.54	136.46	2.63	2.68	2.68	3.61	10.41
HGH55CA	80	13	23.5	100	75	12.5	75	117.7	166.7	27.35	11	12.9	M12x18	17.5	22	29	53	44	23	20	16	120	30	M14x45	114.44	148.33	3.69	2.64	2.64	4.17	15.08
HGH55HA	80	13	23.5	100	75	12.5	75	155.8	204.8	36.4	11	12.9	M12x18	17.5	22	29	53	44	23	20	16	120	30	M14x45	139.35	196.20	4.88	4.57	4.57	5.49	15.08
HGH65CA	90	15	31.5	126	76	25	70	144.2	200.2	43.1	14	12.9	M16x20	25	15	15	63	53	26	22	18	150	35	M16x50	163.63	215.33	6.65	4.27	4.27	7.00	21.18
HGH65HA	90	15	31.5	126	76	25	120	203.6	259.6	47.8	14	12.9	M16x20	25	15	15	63	53	26	22	18	150	35	M16x50	208.36	303.13	9.38	7.38	7.38	9.82	21.18

**HG Series Heavy Load Ball Type**  
**HGH-CA / HGH-HA**

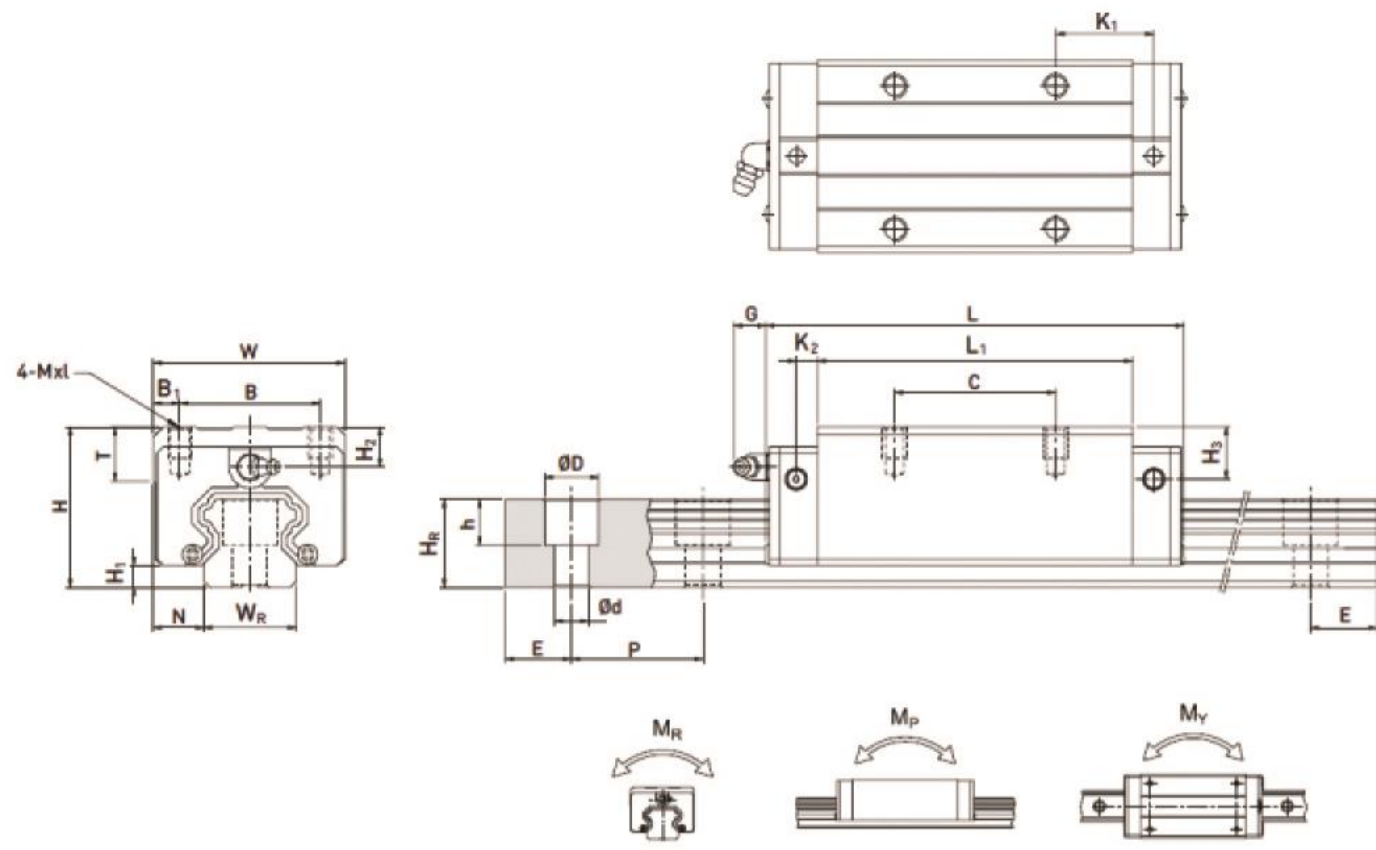

**HG Series Heavy Load Ball Type**  
**HGW-CA / HGW-HA**

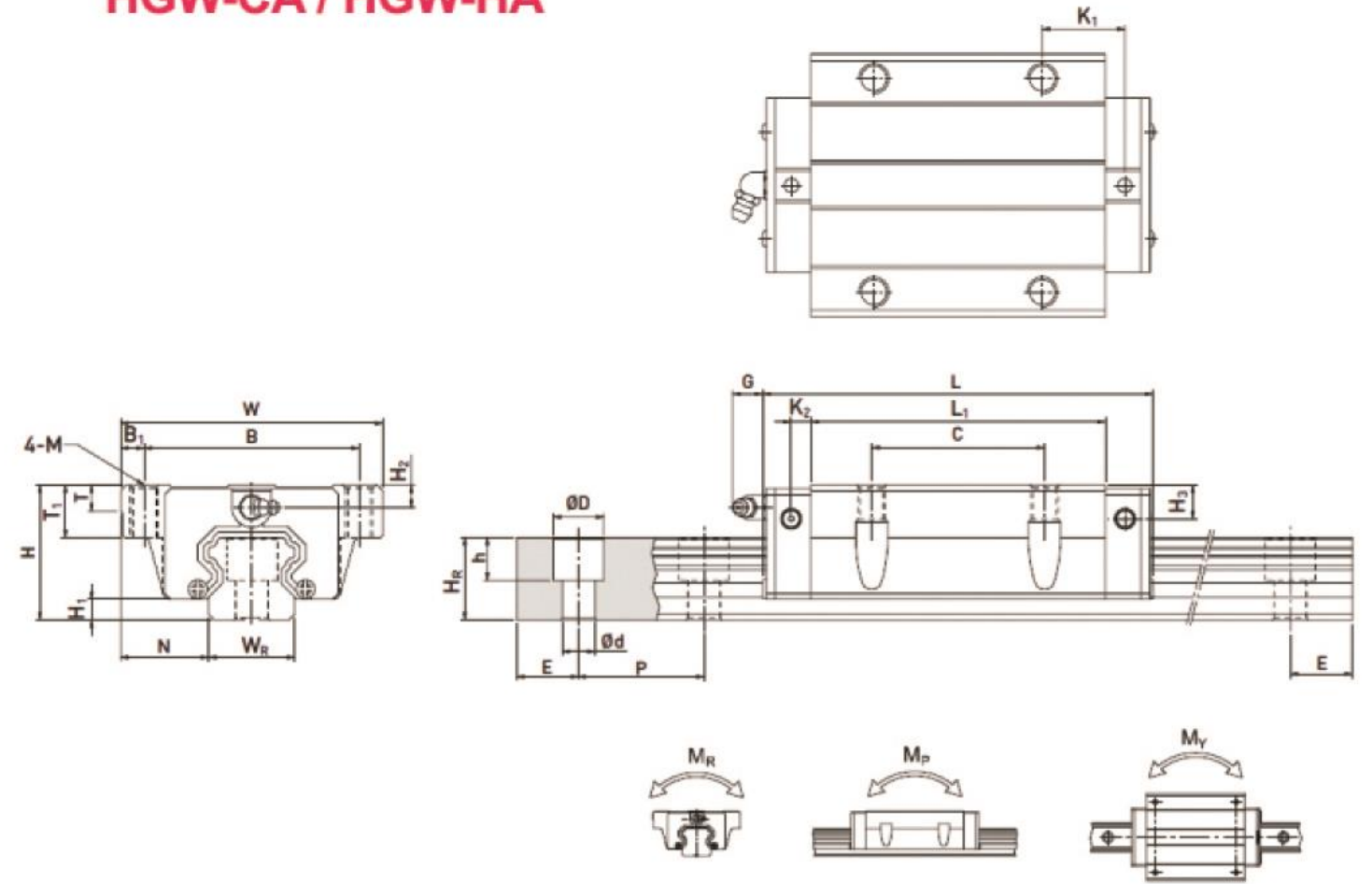

Model No.	Dimensions Of Assembly (mm)			Dimensions Of Block (mm)													Dimensions Of Rail (mm)							Mounting Bolt For Rail (mm)	Basic Dynamic Load Rating C(kN)	Basic Static Load Rating C <sub>0</sub> (kN)	Static Rated Moment			Weight Block Kg	Weight Rail Kg/m	
	H	H <sub>1</sub>	N	W	B	B <sub>1</sub>	C	L <sub>1</sub>	L	K <sub>1</sub>	K <sub>2</sub>	G	M	T	T <sub>1</sub>	H <sub>2</sub>	H <sub>3</sub>	W <sub>R</sub>	H <sub>R</sub>	D	h	d	P				E	M <sub>R</sub>	M <sub>P</sub>			M <sub>Y</sub>
HGW15CA	24	4.3	16	47	38	4.5	30	39.4	61.4	8	4.85	5.3	M5	6	8.9	3.95	3.7	15	15	7.5	5.3	4.5	60	20	M4x16	11.38	16.97	0.12	0.10	0.10	0.17	1.45
HGW20CA	30	4.6	21.5	63	53	5	40	50.5	77.5	10.25	6	12	M6	8	10	6	6	20	17.5	9.5	8.5	6	60	20	M5x16	17.75	27.76	0.27	0.20	0.20	0.40	2.21
HGW20HA	30	4.6	21.5	63	53	5	40	65.2	92.2	17.6	6	12	M6	8	10	6	6	20	17.5	9.5	8.5	6	60	20	M5x16	21.18	35.90	0.35	0.35	0.35	0.52	2.21
HGW25CA	36	5.5	23.5	70	57	6.5	45	58	84	10.7	6	12	M8	8	14	6	5	23	22	11	9	7	60	20	M6x20	26.48	36.49	0.42	0.33	0.33	0.59	3.21
HGW25HA	36	5.5	23.5	70	57	6.5	45	78.6	104.6	21	6	12	M8	8	14	6	5	23	22	11	9	7	60	20	M6x20	32.75	49.44	0.56	0.57	0.57	0.80	3.21
HGW30CA	41	6	31	90	72	9	52	70	97.4	14.25	6	12	M10	8.5	16	6.5	10.8	28	26	14	12	9	80	20	M8x25	38.74	52.19	0.66	0.53	0.53	1.09	4.47
HGW30HA	41	6	31	90	72	9	52	93	120.4	25.75	6	12	M10	8.5	16	6.5	10.8	28	26	14	12	9	80	20	M8x25	47.27	69.16	0.88	0.92	0.92	1.44	4.47
HGW35CA	48	7.5	33	100	82	9	62	80	112.4	14.6	7	12	M10	10.1	18	9	12.6	34	29	14	12	9	80	20	M8x25	49.52	69.16	1.16	0.81	0.81	1.56	6.30
HGW35HA	48	7.5	33	100	82	9	62	105.8	138.2	27.5	7	12	M10	10.1	18	9	12.6	34	29	14	12	9	80	20	M8x25	60.21	91.63	1.54	1.40	1.40	2.06	6.30
HGW45CA	60	9.5	37.5	120	100	10	80	97	139.4	13	10	12.9	M12	15.1	22	8.5	20.5	45	38	20	17	14	105	22.5	M12x35	77.57	102.71	1.98	1.55	1.55	2.79	10.41
HGW45HA	60	9.5	37.5	120	100	10	80	128.8	171.2	28.9	10	12.9	M12	15.1	22	8.5	20.5	45	38	20	17	14	105	22.5	M12x35	94.54	136.46	2.63	2.68	2.68	3.69	10.41
HGW55CA	70	13	43.5	140	116	12	95	117.7	166.7	17.35	11	12.9	M14	17.5	26.5	12	19	53	44	23	20	16	120	30	M14x45	114.44	148.33	3.69	2.64	2.64	4.52	15.08
HGW55HA	70	13	43.5	140	116	12	95	155.8	204.8	36.4	11	12.9	M14	17.5	26.5	12	19	53	44	23	20	16	120	30	M14x45	139.35	196.20	4.88	4.57	4.57	5.96	15.08
HGW65CA	90	15	53.5	170	142	14	110	144.2	200.2	23.1	14	12.9	M16	25	37.5	15	15	63	53	26	22	18	150	35	M16x50	163.63	215.33	6.65	4.27	4.27	9.17	21.18
HGW65HA	90	15	53.5	170	142	14	110	203.6	259.6	52.8	14	12.9	M16	25	37.5	15	15	63	53	26	22	18	150	35	M16x50	208.36	303.13	9.38	7.38	7.38	12.89	21.18



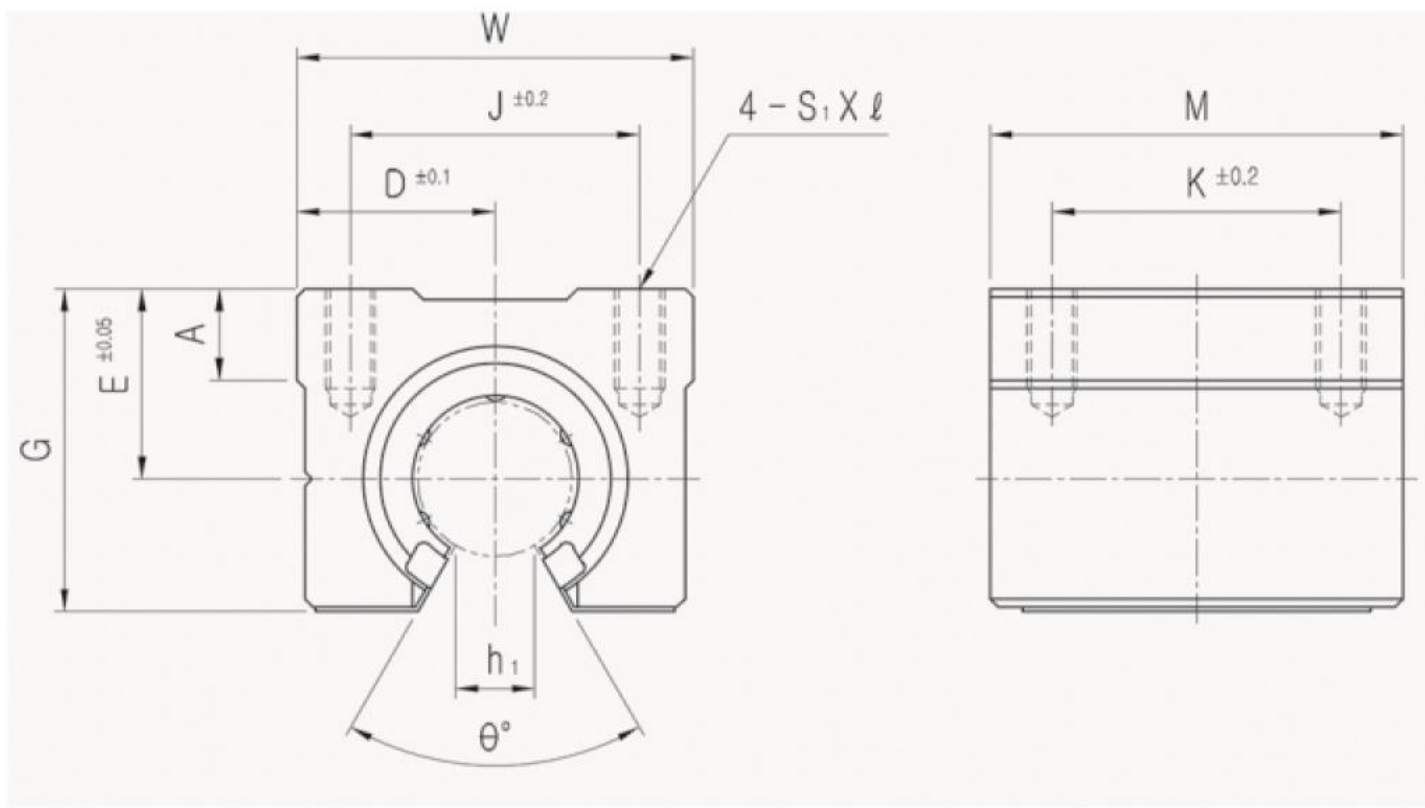

### SBR Aluminum Case Unit Open

Part No.	L/B	D	W	G	θ	A	M	Sxφ	h1
SBR16UU	LM16UUOP	22.5	45	33	80°	9	45	M5x12	11
SBR20UU	LM20UUOP	24	48	39	60°	11	50	M6x12	11
SBR25UU	LM25UUOP	30	60	47	50°	14	65	M6x12	12
SBR30UU	LM30UUOP	35	70	56	50°	15	70	M8x18	15
SBR35UU	LM35UUOP	40	80	63	50°	18	80	M8x18	17
SBR40UU	LM40UUOP	45	90	72	50°	20	90	M10x20	20
SBR50UU	LM50UUOP	60	120	91	50°	25	110	M10x20	25

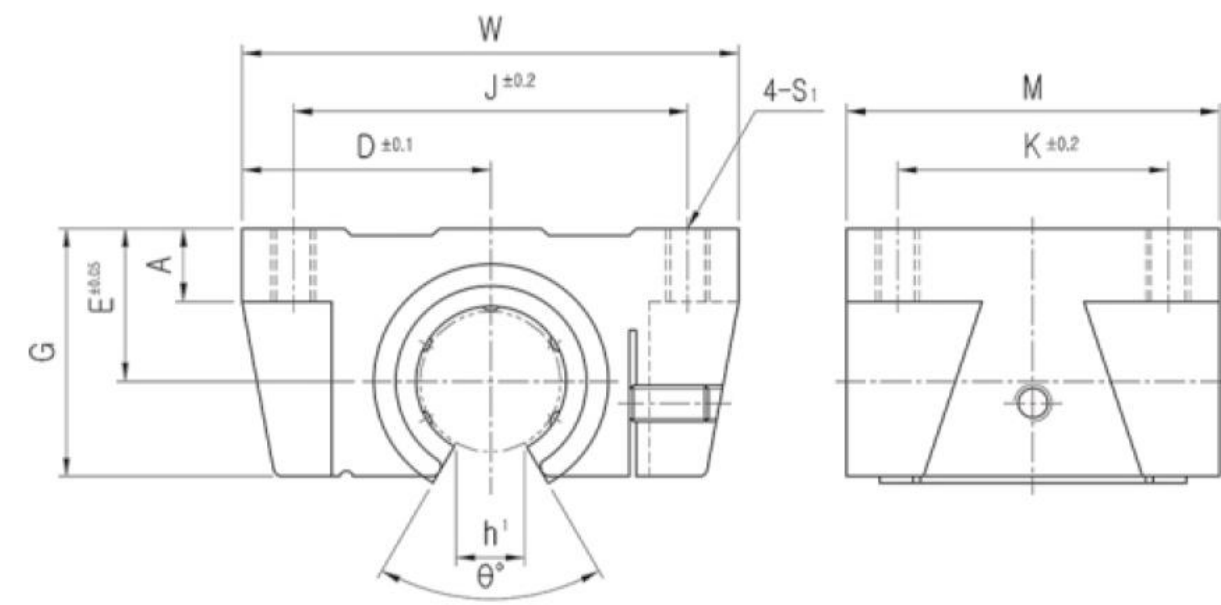

### TBR Aluminum Case Unit Open

Part No.	L/B	D	W	G	θ	A	M	S1	h1	E
TBR16UU	LM16UUOP	31	62	26	80°	8	42	M5	11	18
TBR20UU	LM20UUOP	34	68	31	60°	10	51	M6	11	21
TBR25UU	LM25UUOP	41	82	41	50°	12	65	M8	12	28
TBR30UU	LM30UUOP	45.5	91	48	50°	12	75	M8	15	34

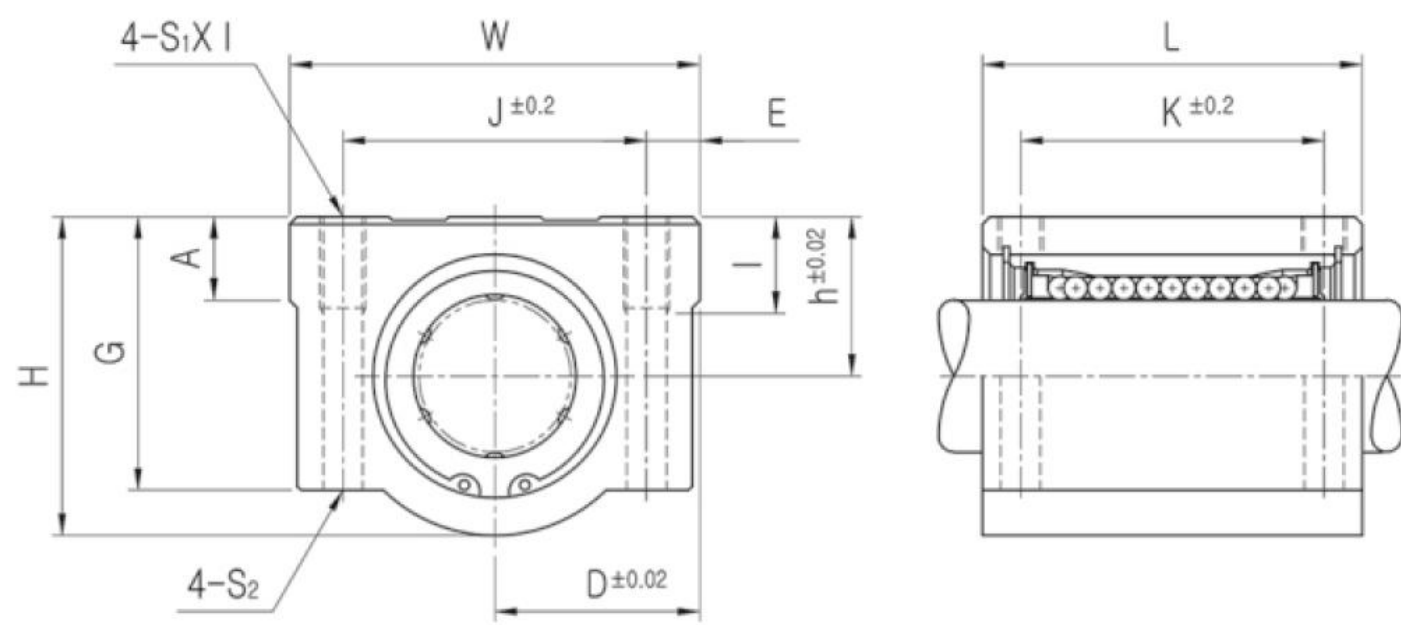

### SCE ALUMINIUM Case Closed

Part No.	L / B	h	D	W	H	G	A	J	E
SC8UU-B	LM8UU	11	17	34	22	18	6	24	5
SC10UU-B	LM10UU	13	20	40	26	21	8	28	6
SC12UU-B	LM12UU	15	22	44	30	24.5	8	33	5.5
SC12UU-B	LM12UU	15	21	42	28	24	7.4	30.5	5.75
SC13UU-B	LM13UU	15	22	44	30	24.5	8	33	5.5
SC16UU-B	LM16UU	19	25	50	38.5	32.5	9	36	7
SC20UU-B	LM20UU	21	27	54	41	35	11	40	7
SC25UU-B	LM25UU	26	38	76	51.5	41	12	54	11
SC30UU-B	LM30UU	30	39	78	59.5	49	15	58	10
SC35UU-B	LM35UU	34	45	90	68	54	18	70	10
SC40UU-B	LM40UU	40	51	102	78	62	20	80	11
SC50UU-B	LM50UU	52	61	122	102	80	24	100	11

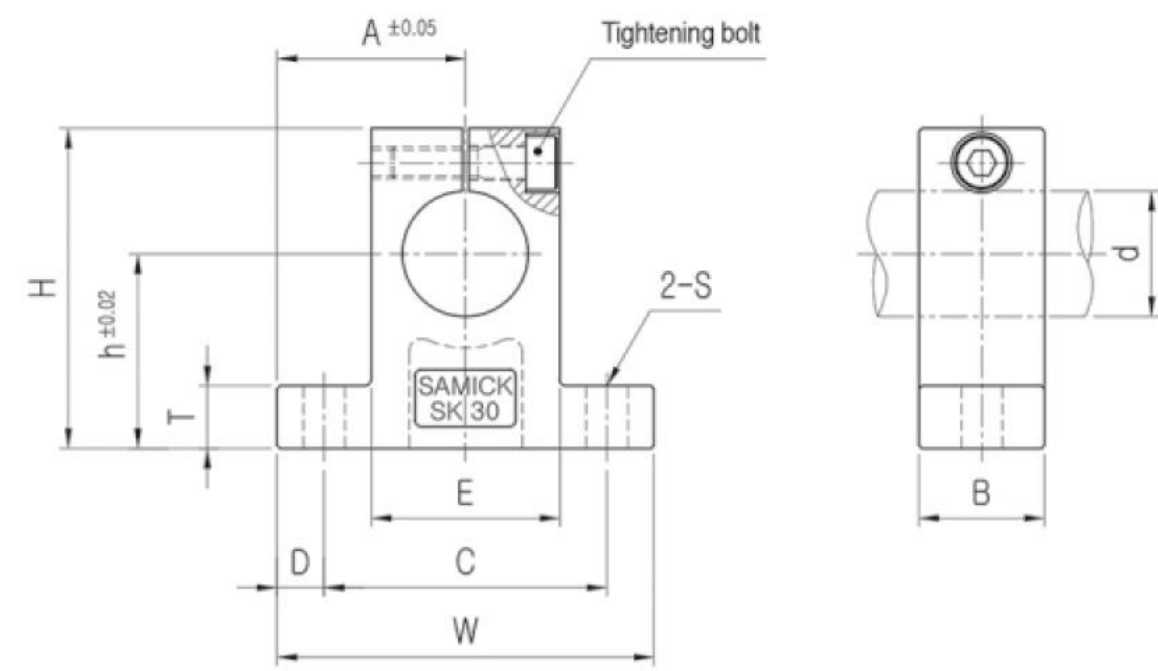

### SK Shaft Support

Part No.	LM Shaft Diameter	h	A	W	H	T	E	D	C	B
SK8	Φ8	20	21	42	32.8	6	18	5	32	14
SK10	Φ10	20	21	42	32.8	6	18	5	32	14
SK12	Φ12	23	21	42	38	6	20	5	32	14
SK13	Φ13	23	21	42	38	6	20	5	32	14
SK16	Φ16	27	24	48	44	8	25	5	38	16
SK20	Φ20	31	30	60	51	10	30	7.5	45	20
SK25	Φ25	35	35	70	60	12	38	7	56	24
SK30	Φ30	42	42	84	70	12	44	10	64	28
SK35	Φ35	50	49	98	85	15	50	12	74	32
SK40	Φ40	60	57	114	96	15	60	12	90	36



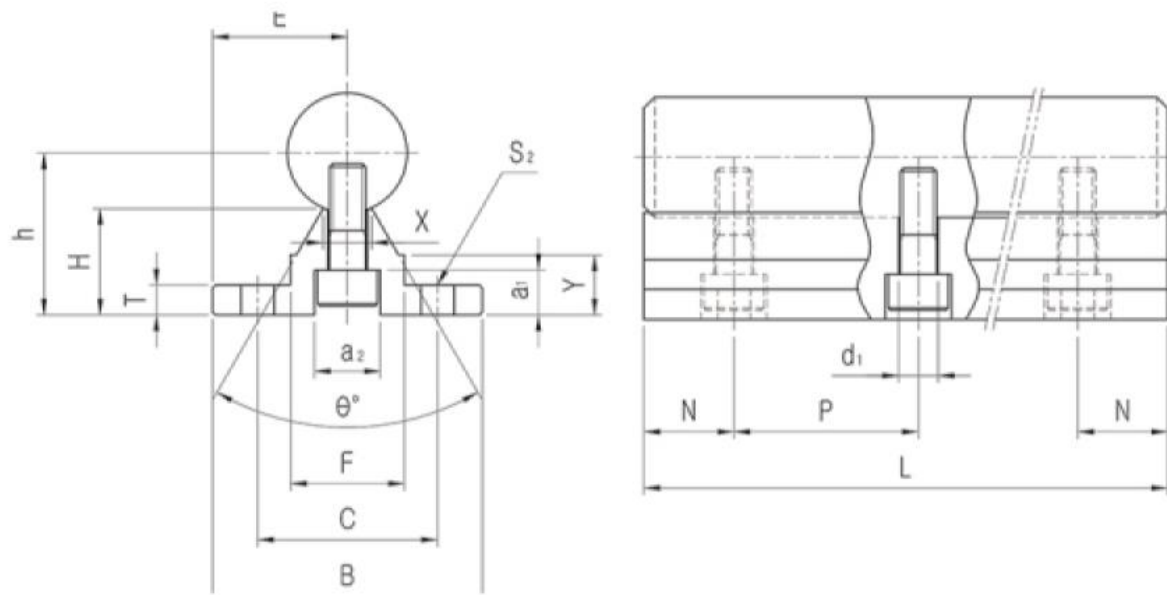

### SBS Support Rail Unit

Part No.	LM Shaft Outer Diameter	E	h	B	H	T	F	X	Y	C
SBS16	Φ16	20	25	40	17.79	5	18.5	8	11.7	30
SBS20	Φ20	22.5	27	45	17.72	5	19	8	10	30
SBS30	Φ25	27.5	33	55	21.13	6	21.5	8	12	35
SBS35	Φ30	30	37	60	22.85	7	26.5	10.3	13	40
SBS35	Φ35	32.5	43	65	26.62	8	28	13	15.5	45
SBS40	Φ40	37.5	78	75	29.43	9	38	16	17	55
SBS50	Φ50	47.5	62	95	38.79	11	45	20	21	70

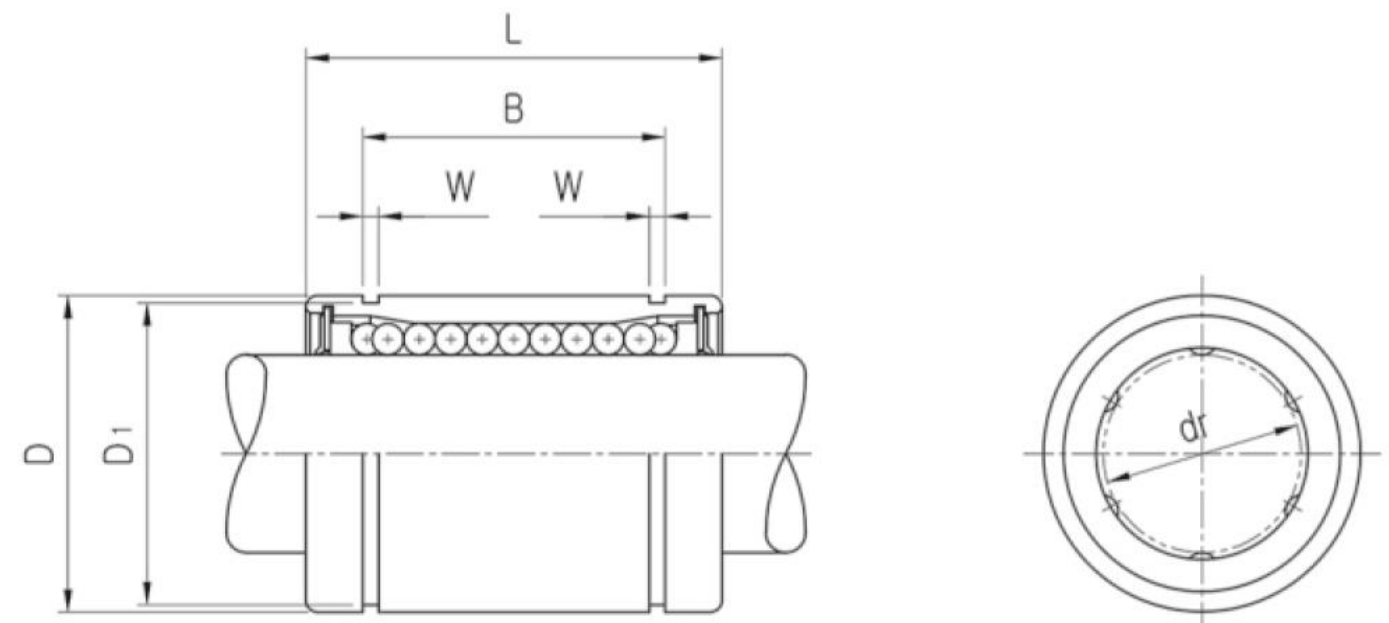

### LME Closed Linear Bushing

Part No.		Working Bore Diameter		D	
Resin	Steel	dr. (mm)	Clear NCE (mm)	dr. (mm)	Clear NCE (mm)
LME5UU-SUS	LME-5-A	5		12	
LME8UU-SUS	LME-8-A	8	+0.008	16	0 / -0.008
LME12UU-SUS	LME-12-A	12		22	
LME16UU-SUS	LME-16-A	16	+0.009 / -0.001	26	0 / -0.009
LME20UU-SUS	LME-20-A	20		32	
LME25UU-SUS	LME-25-A	25	0 / -0.011	40	0 / -0.011

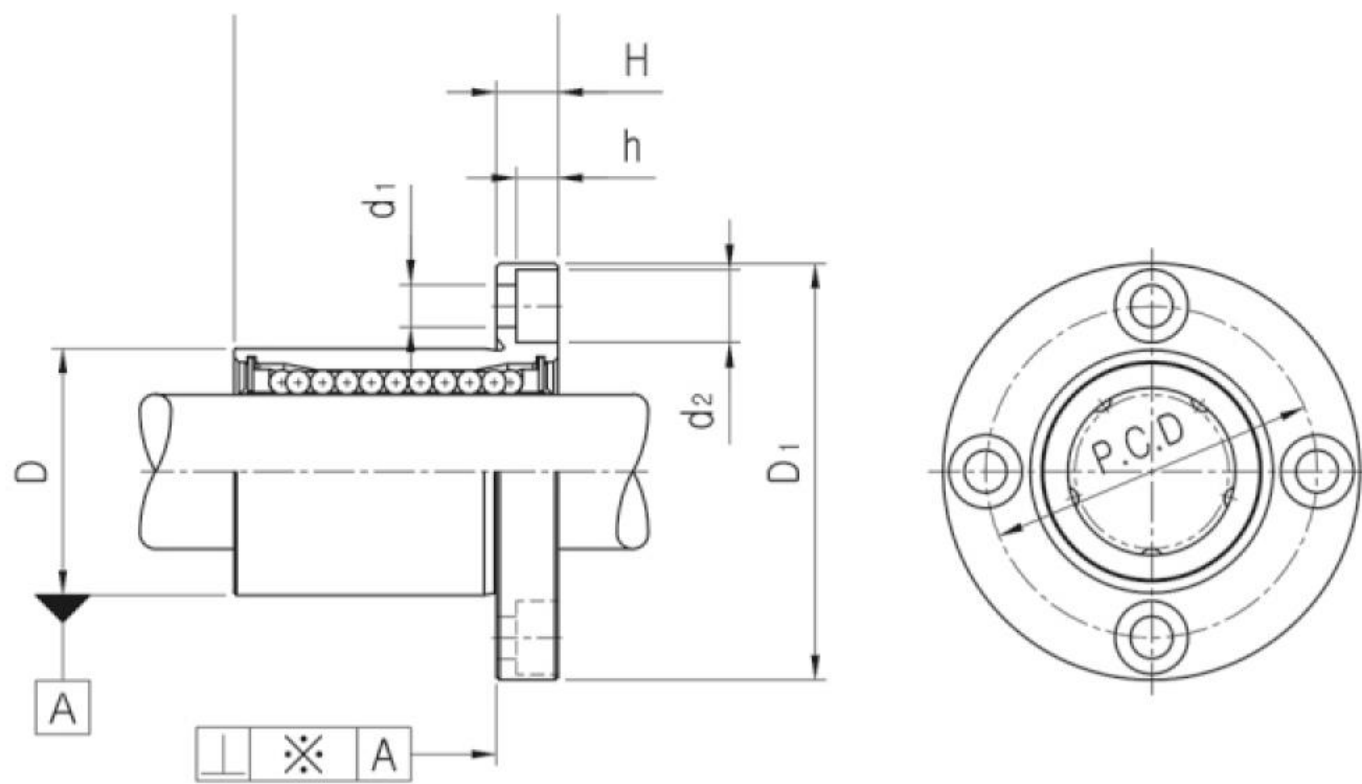

### LMF Flanged Linear Bushing

Part No.		Working Bore Diameter		D	
Resin	Steel	dr. (mm)	Clear NCE (mm)	dr. (mm)	Clear NCE (mm)
LMF6UU-SUS	LMF-6-A	6		12	
LMF8UU-SUS		8		15	0 / -0.011
LMF8UU-SUS	LMF-8-A	8		15	
LMF10UU-SUS	LMF-10-A	10	0 / -0.009	19	
LMF12UU-SUS	LMF-12-A	12		21	0 / -0.013
LMF13UU-SUS	LMF-13-A	13		23	
LMF16UU-SUS	LMF-16-A	16		28	
LMF20UU-SUS	LMF-20-A	20		32	
LMF25UU-SUS	LMF-25-A	25	0 / -0.010	40	0 / -0.016
LMF30UU-SUS		30		45	
LMF35UU-SUS		35		52	
LMF40UU-SUS		40	0 / -0.012	60	0 / -0.019
LMF50UU-SUS		50		80	

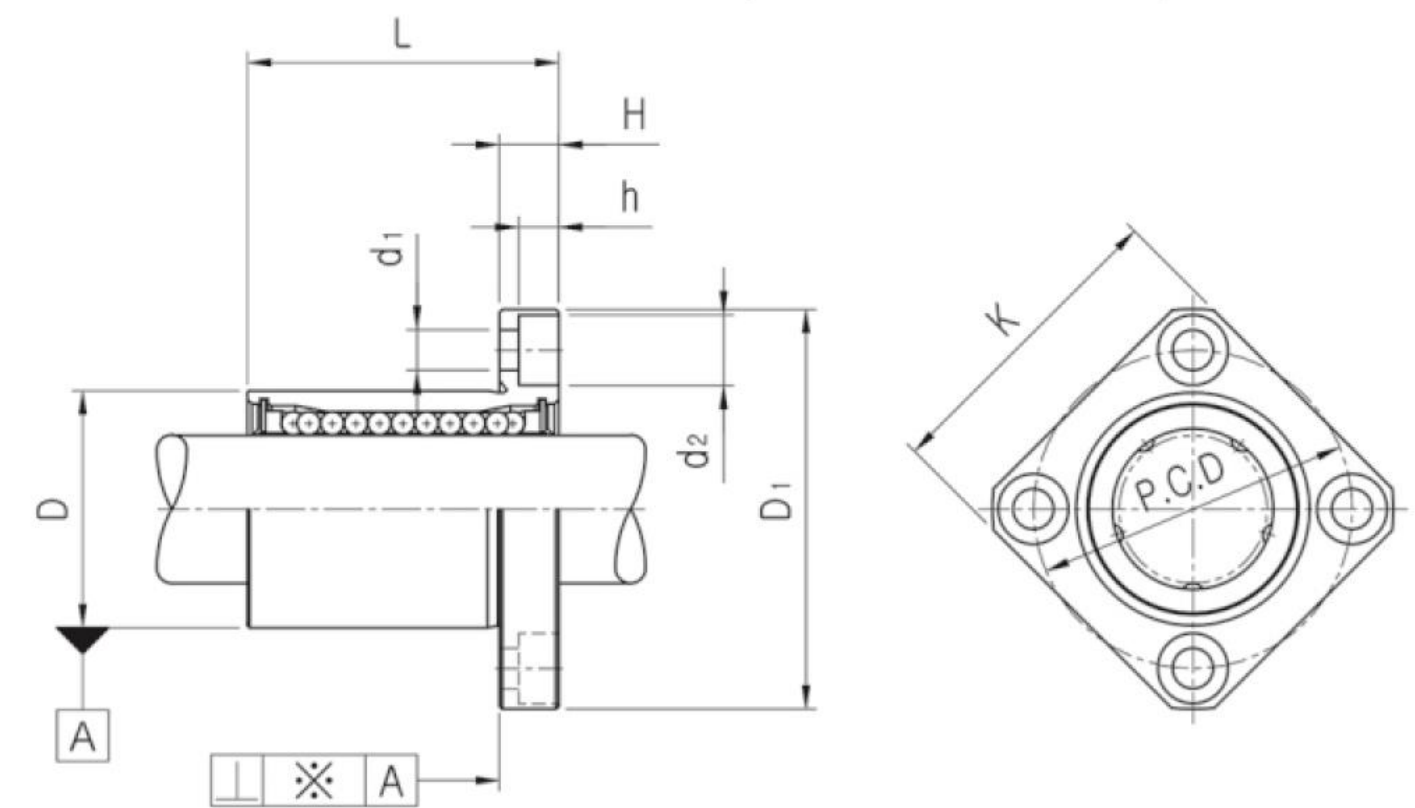

### LMK Flanged Linear Bushing

Part No.		Working Bore Diameter		D	
Resin	Steel	dr. (mm)	Clear NCE (mm)	dr. (mm)	Clear NCE (mm)
LMK6UU-SUS	LMK-6-A	6		12	
LMK8UU-SUS		8		15	0 / -0.011
LMK8UU-SUS	LMK-8-A	8		15	
LMK10UU-SUS	LMK-10-A	10	0 / -0.009	19	
LMK12UU-SUS	LMK-12-A	12		21	0 / -0.013
LMK13UU-SUS	LMK-13-A	13		23	
LMK16UU-SUS	LMK-16-A	16		28	
LMK20UU-SUS	LMK-25-A	20		32	
LMK25UU-SUS		25	0 / -0.010	40	0 / -0.016
LMK30UU-SUS		30		45	
LMK35UU-SUS		35		52	
LMK40UU-SUS		40	0 / -0.012	60	0 / -0.019
LMK50UU-SUS		50		80	





## LB Series [L1 Single Stage]

### Standard Type Planetary Reducers

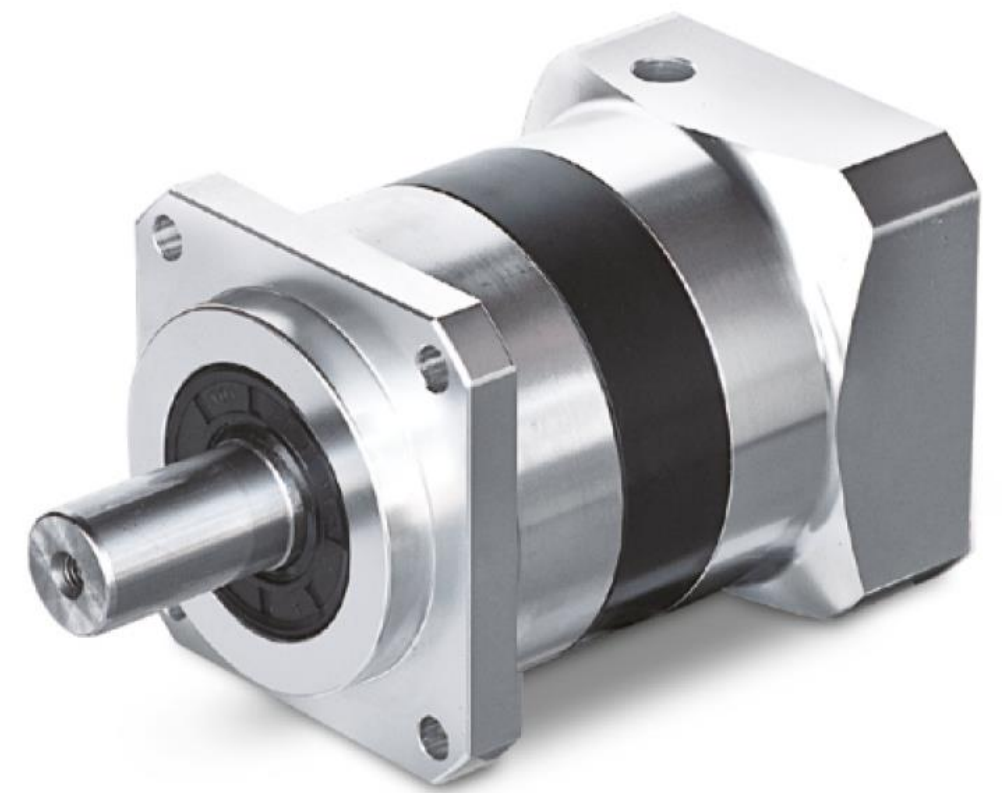

Satge	L1 (Single Stage)
Speed Ratio	3, 4, 5, 7, 10

Specification :	
Gear Ratio	10:1
Rated Torque	45 N.m
Instant Stop Torque	2 Times of rated torque
Max Ratial Torque	650 N
Max Axial Torque	900 N
Full Load Efficiency	96%
Intetia	0.34 kgcm
Backlash	<8arcmin
Noise	60dB(A),distance 1m

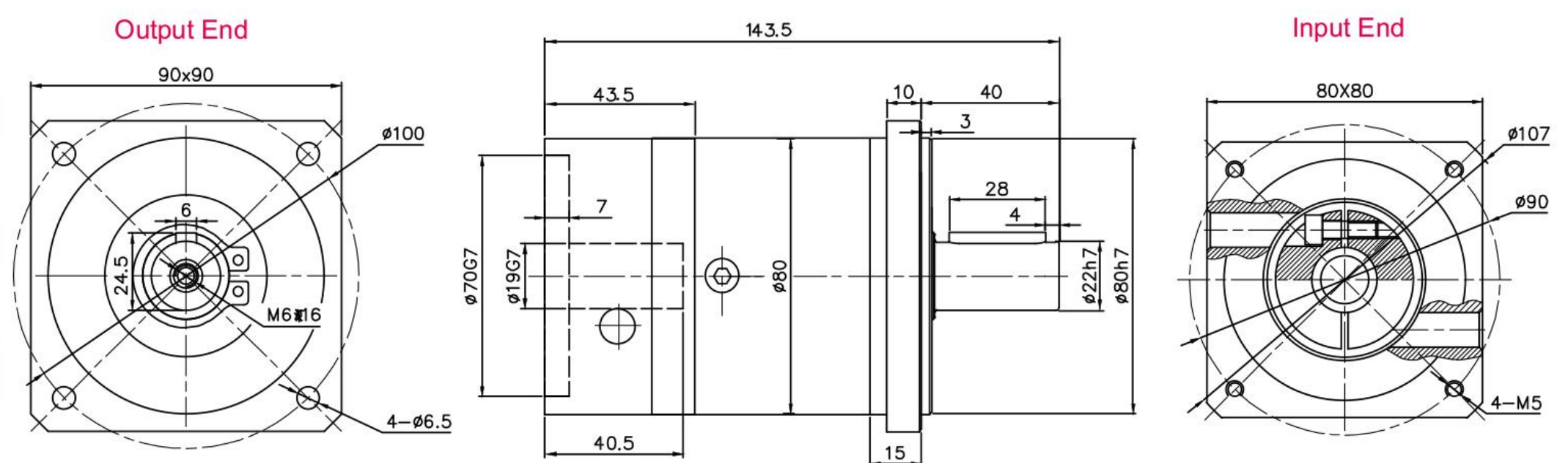

Technical Date:	
Gear Ratio	10:1
Rated Torque	15 N.m
Instant Stop Torque	2 Times of rated torque
Max Ratial Torque	340 N
Max Axial Torque	450 N
Full Load Efficiency	96%
Intetia	0.078 kgcm
Backlash	<8arcmin
Noise	60dB(A),distance 1m

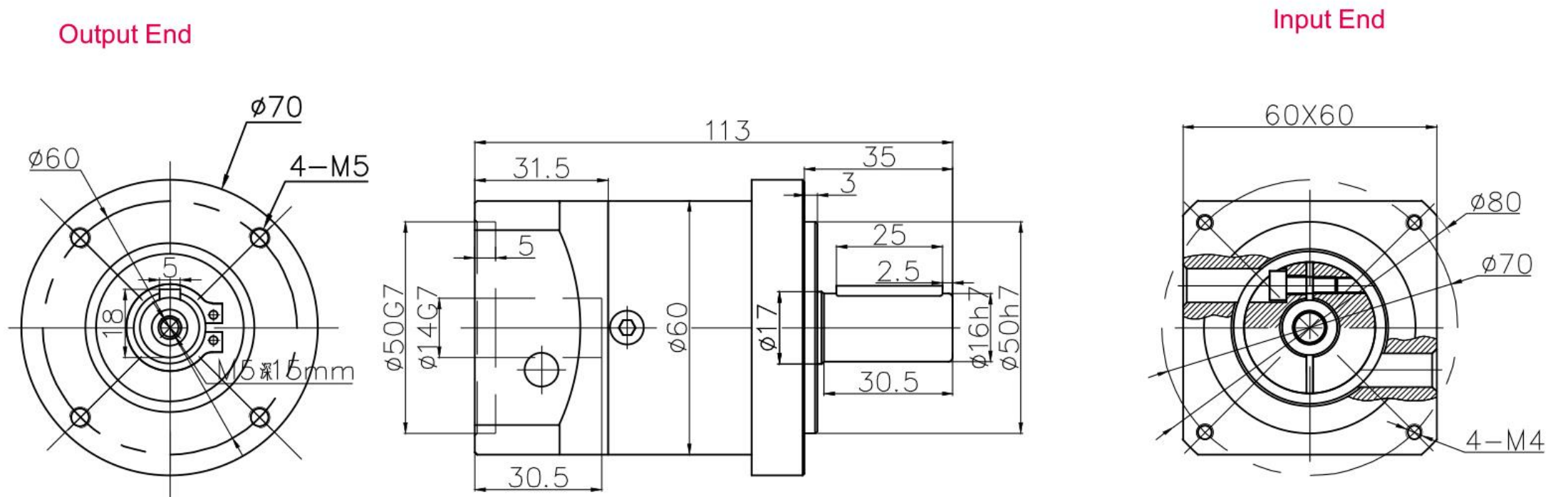



## LB Series [L2 Double Stage]

### Standard Type Planetary Reducers

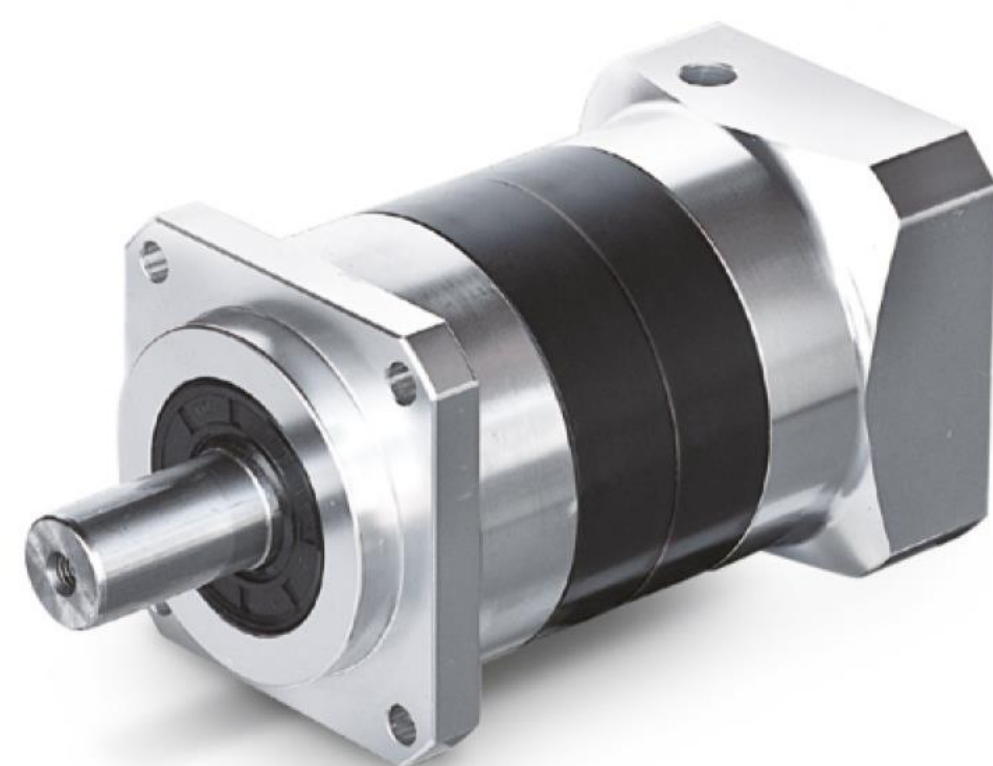

Satge	L2 (Double Stage)
Speed Ratio	15, 20, 25, 30, 35, 40, 50, 70, 100

Specification :	
Gear Ratio	25:1
Rated Torque	120 N.m
Instant Stop Torque	2 Times of rated torque
Max Ratial Torque	650 N
Max Axial Torque	900 N
Full Load Efficiency	96%
Intetia	0.44 kgcm
Backlash	<10arcmin
Noise	60dB(A),distance 1m

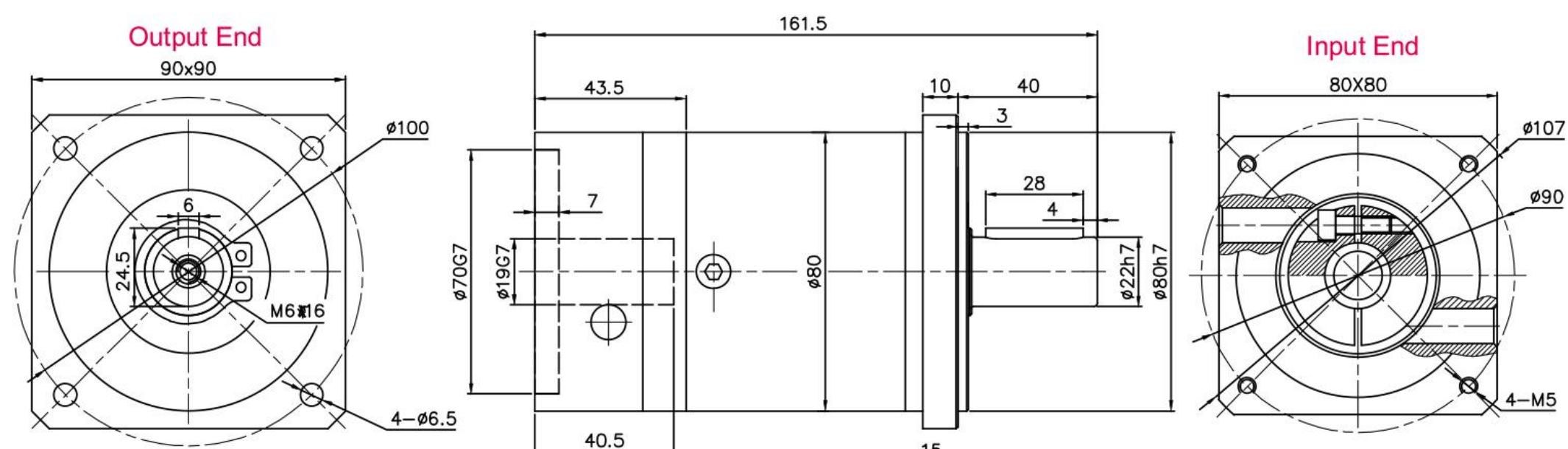

Specification :	
Gear Ratio	25:1
Rated Torque	40 N.m
Instant Stop Torque	2 Times of rated torque
Max Ratial Torque	240 N
Max Axial Torque	450 N
Full Load Efficiency	94%
Intetia	0.064 kgcm
Backlash	<10arcmin
Noise	60dB(A),distance 1m

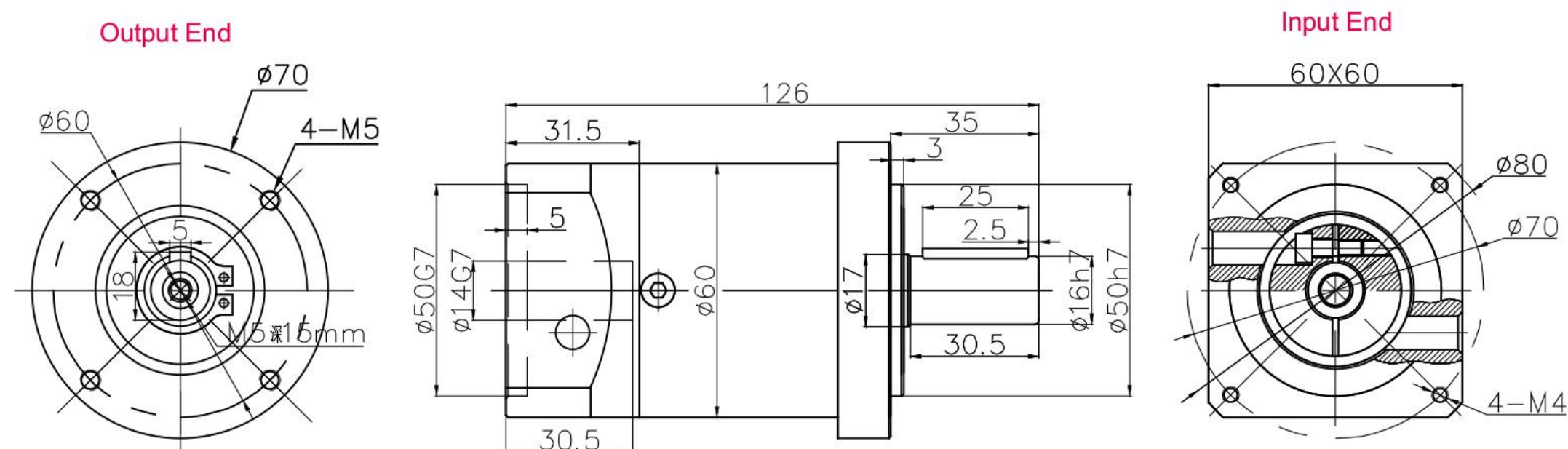





## LE Series [L1 Single Stage]

### Circular Flange Type Planetary Reducers

Satge	L1 (Single Stage)
Speed Ratio	3, 4, 5, 7, 10

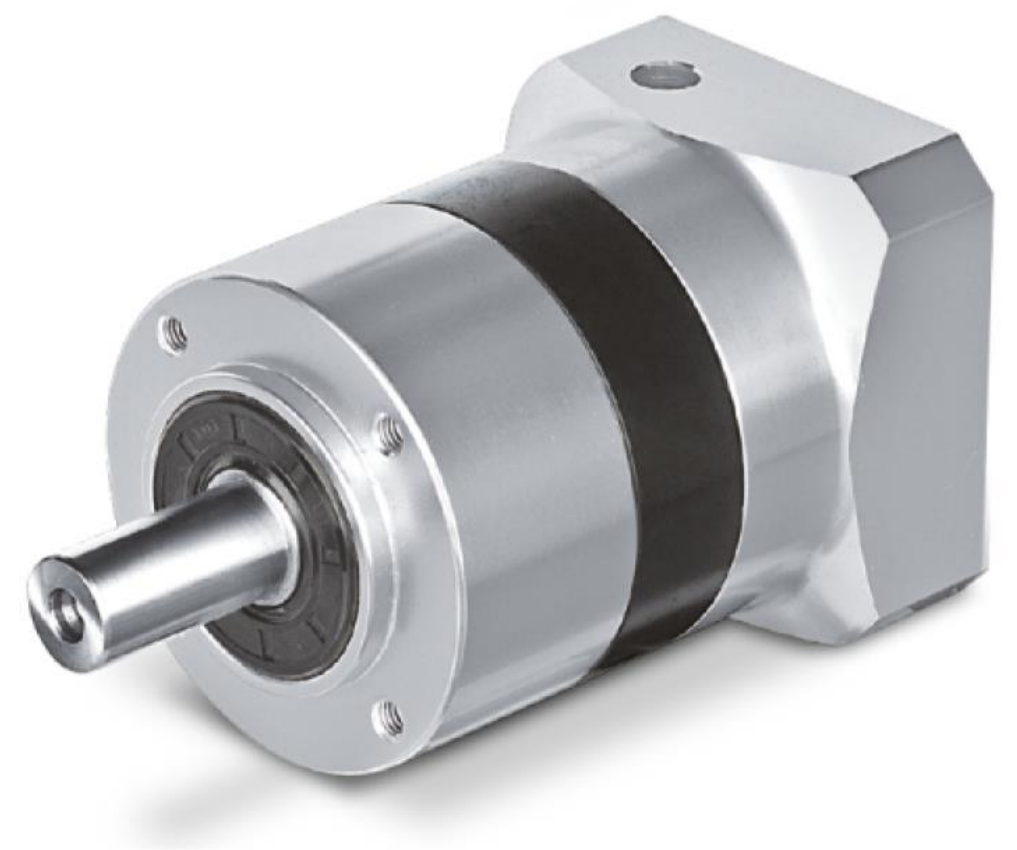

Technical Data :	
Gear Ratio	10:1
Rated Torque	45 N.m
Instant Stop Torque	2 Times of rated torque
Max Ratial Torque	650 N
Max Axial Torque	900 N
Full Load Efficiency	96%
Intetia	0.45 kgcm
Backlash	<10arcmin
Noise	60dB(A),distance 1m

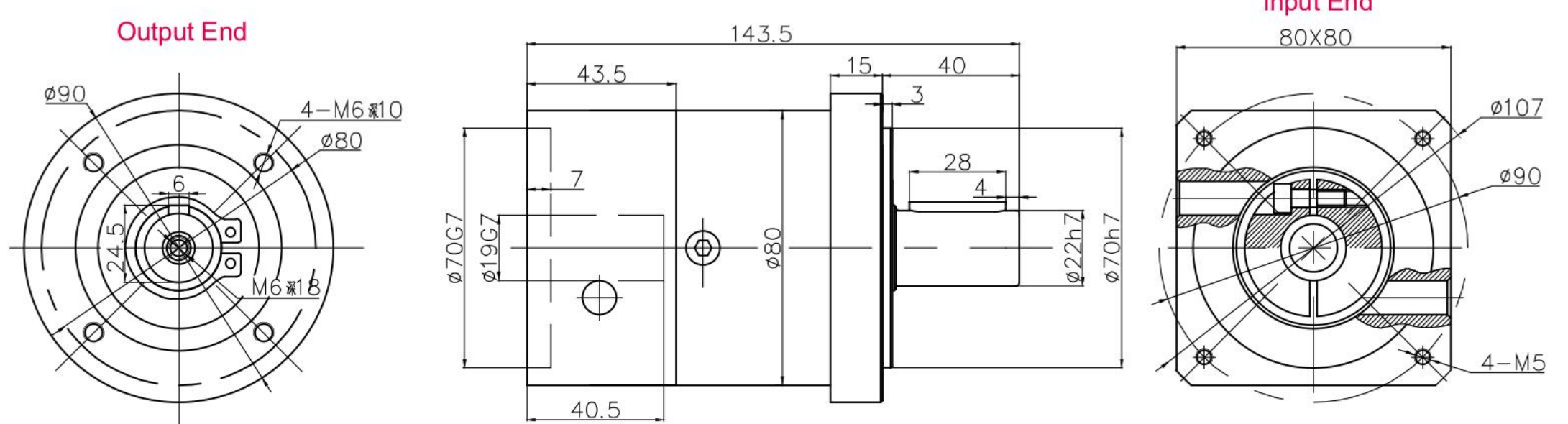

Technical Data :	
Gear Ratio	10:1
Rated Torque	15 N.m
Instant Stop Torque	2 Times of rated torque
Max Ratial Torque	340 N
Max Axial Torque	450 N
Full Load Efficiency	96%
Intetia	0.078 kgcm
Backlash	<8arcmin
Noise	60dB(A),distance 1m

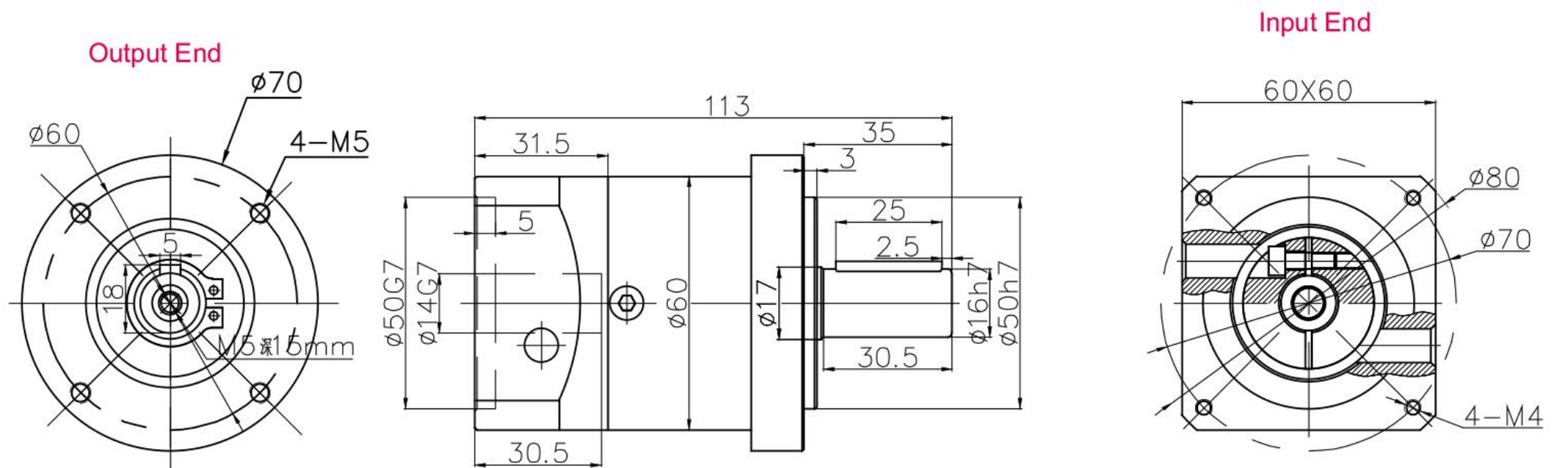



## LE Series [L2 Double Stage]

### Circular Flange Type Planetary Reducers



Satge	L2 (Double Stage)
Speed Ratio	15,20,25,30,35,40,50,70,100

Technical Data :	
Gear Ratio	25:1
Rated Torque	110 N.m
Instant Stop Torque	2 Times of rated torque
Max Radial Torque	650 N
Max Axial Torque	900 N
Full Load Efficiency	94%
Intetia	0.39 kgcm
Backlash	<10arcmin
Noise	60dB(A),distance 1m

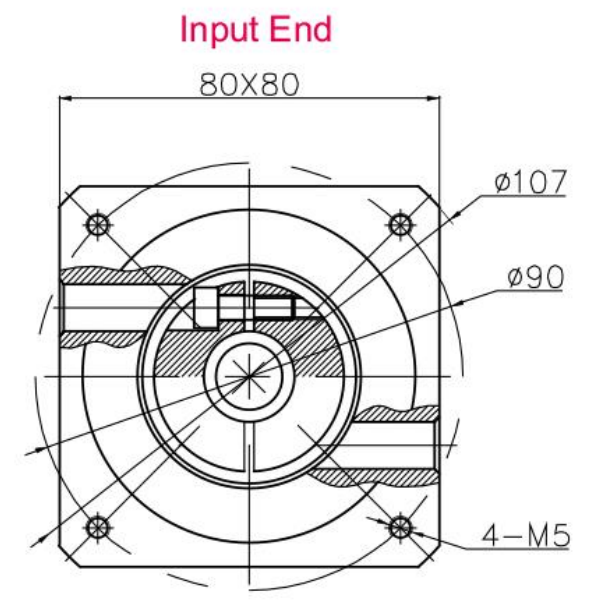
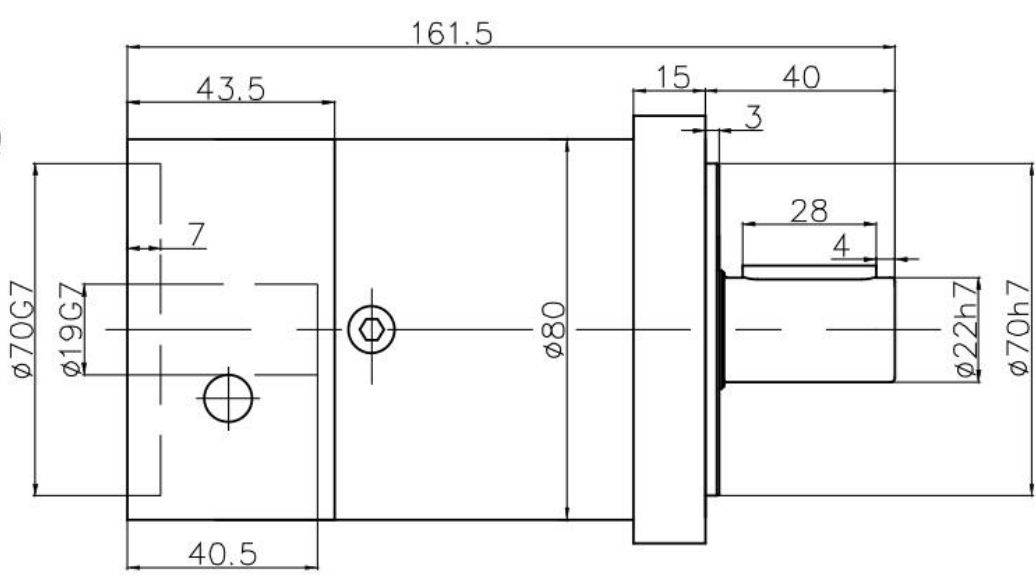
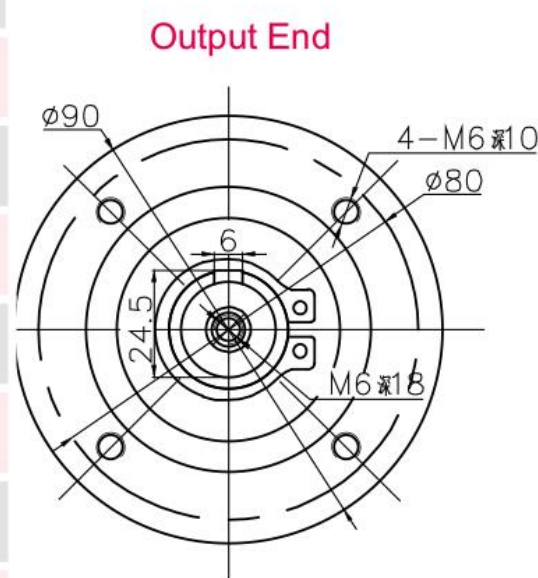

Technical Data :	
Gear Ratio	25:1
Rated Torque	40 N.m
Instant Stop Torque	2 Times of rated torque
Max Radial Torque	240 N
Max Axial Torque	450 N
Full Load Efficiency	94%
Intetia	0.064 kgcm
Backlash	<10arcmin
Noise	60dB(A),distance 1m

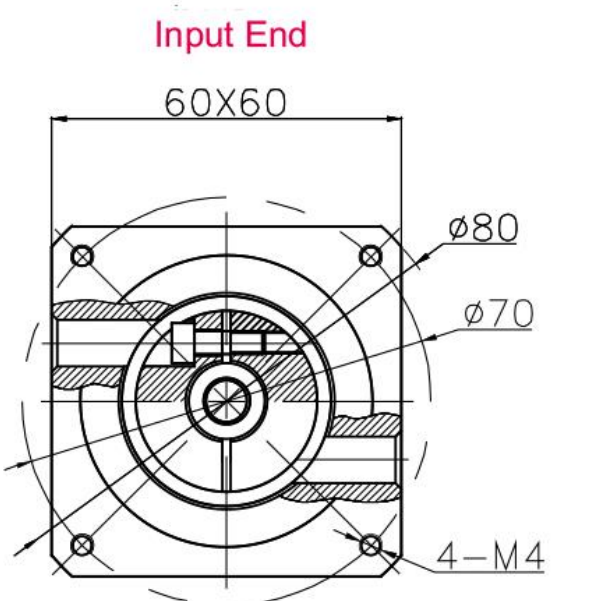
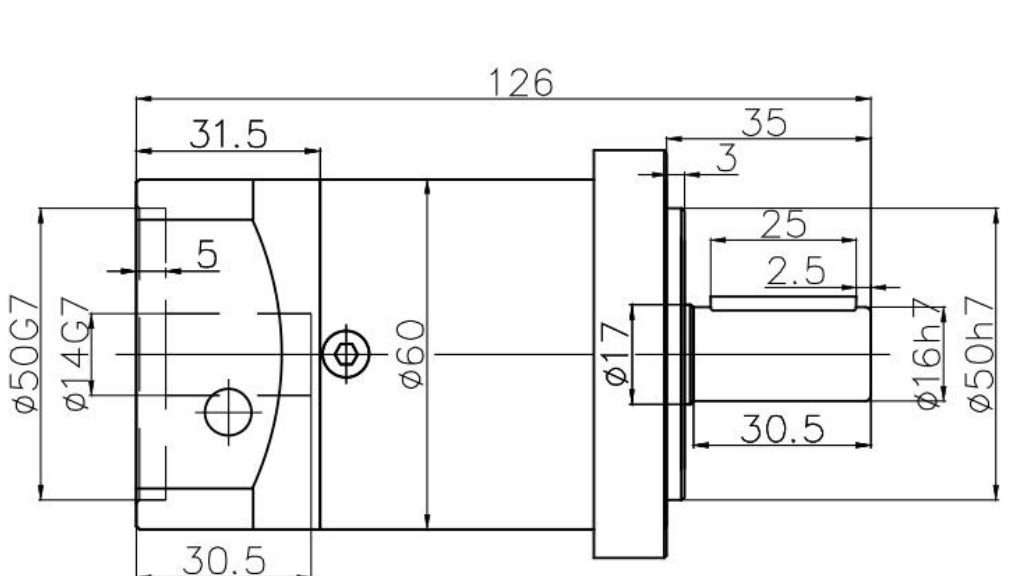
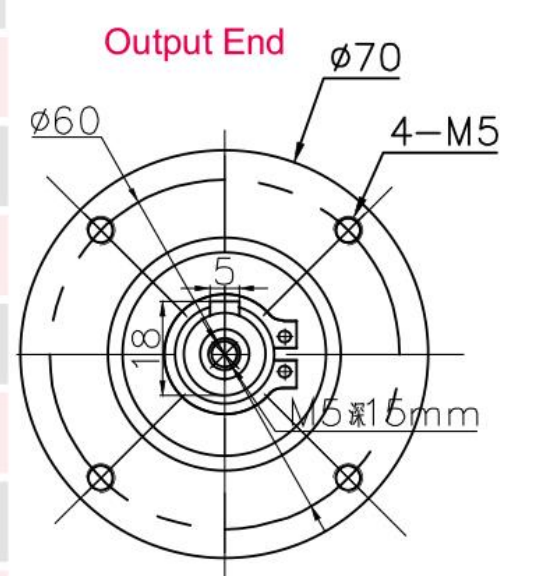



## SE 60 Series [Single & Double Stage] Circular Flange Type Helical Planetary Reducers



Technical Data :	
Full Load efficiency	95 %
Rated input speed	3000 min <sup>-1</sup>
Operating temperature	2 Times of rated torque
Maximum input speed	650 N
Lubrication	Synthetic grease lubrication
Installation	arbitrary
Full load efficiency	95 %
Life expectancy	20000 H
Weight	3.7 Kg
Return clearance	& 1 t ; 3 arcmin
Return gap (economic type)	& 1 t ; 5 arcmin
Maximum allowable radial load	2400 N
Allow maximum axial load	2200 N
Maker size	∅14x 30/∅ 50 x 3/4 - ∅5.5 - ∅70

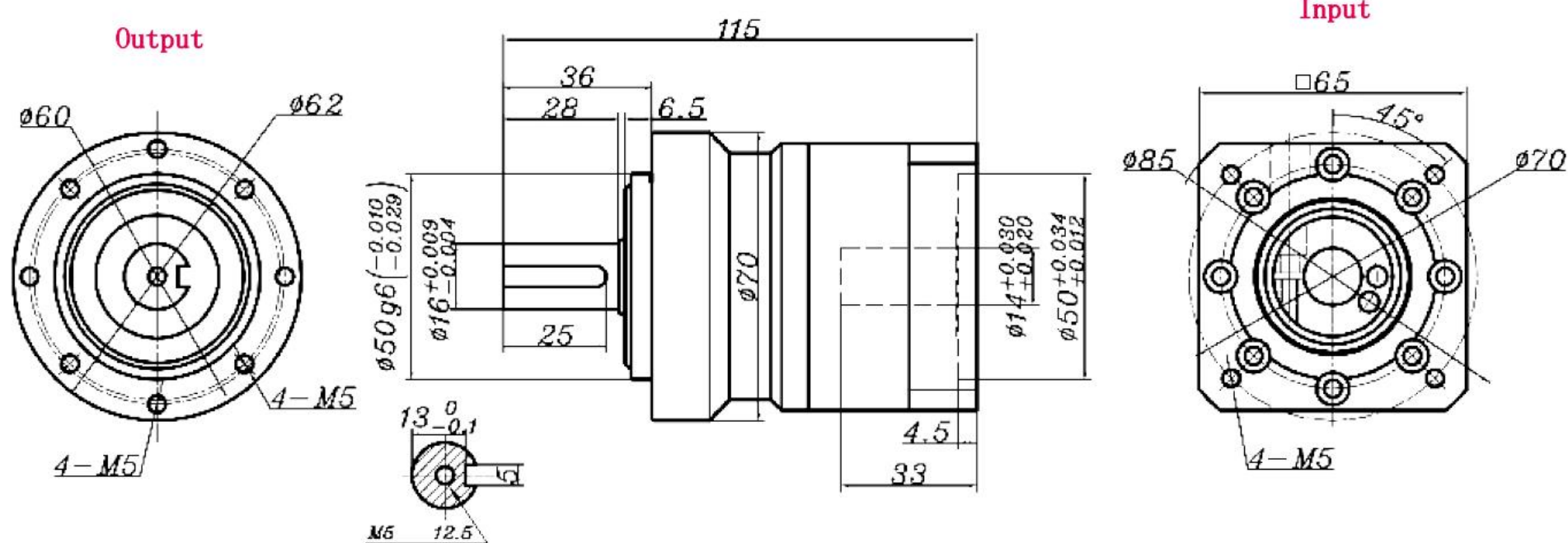

	3	4	5	7	9	10
Rate output torque	18 Nm	27Nm	27Nm	75Nm	18Nm	18Nm
Fault stop torque	80Nm	100Nm	100Nm	100Nm	80Nm	80Nm
Moment of inertia	0.22Kgcm <sup>2</sup>	0.17Kgcm <sup>2</sup>	0.16Kgcm <sup>2</sup>	0.14Kgcm <sup>2</sup>	0.14Kgcm <sup>2</sup>	0.14Kgcm <sup>2</sup>
Allow radial load	430 N	470N	510N	620N	620N	640N
Allow axial load	310 N	360N	390N	510N	510N	530N

Technical Data :	
Full Load efficiency	95 %
Rated input speed	3000 min <sup>-1</sup>
Operating temperature	-25° ~ -25° + 90°
Maximum input speed	6000 min <sup>-1</sup>
Lubrication	Synthetic grease lubrication
Installation	arbitrary
Full load efficiency	95 %
Life expectancy	20000 H
Weight	3.7 Kg
Return clearance	& 1 t ; 3 arcmin
Return gap (economic type)	& 1 t ; 5 arcmin
Maximum allowable radial load	2400 N
Allow maximum axial load	2200 N
Maker size	∅14x 30/∅ 50 x 3/4 - ∅5.5 - ∅70

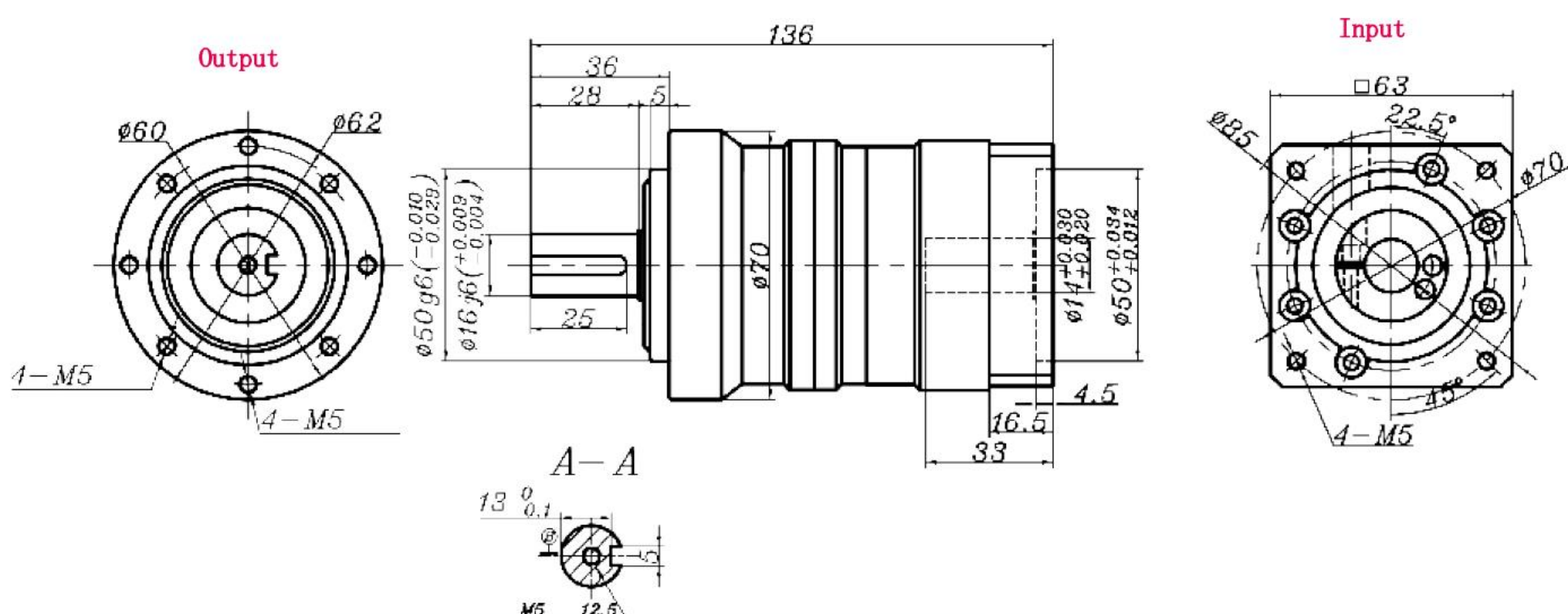

	15	16	20	25	28	30
Rate output torque	18 Nm	27Nm	27Nm	75Nm	18Nm	18Nm
Fault stop torque	80Nm	100Nm	100Nm	100Nm	100Nm	80Nm
Moment of inertia	0.14Kgcm <sup>2</sup>	0.14Kgcm <sup>2</sup>	0.13Kgcm <sup>2</sup>	0.13Kgcm <sup>2</sup>	0.13Kgcm <sup>2</sup>	0.13Kgcm <sup>2</sup>
Allow radial load	740 N	750N	810N	870N	910N	930N
Allow axial load	630 N	650N	720N	790N	830N	860N



## SE 90 Series [Single & Double Stage]

### Circular Flange Type Helical Planetary Reducers

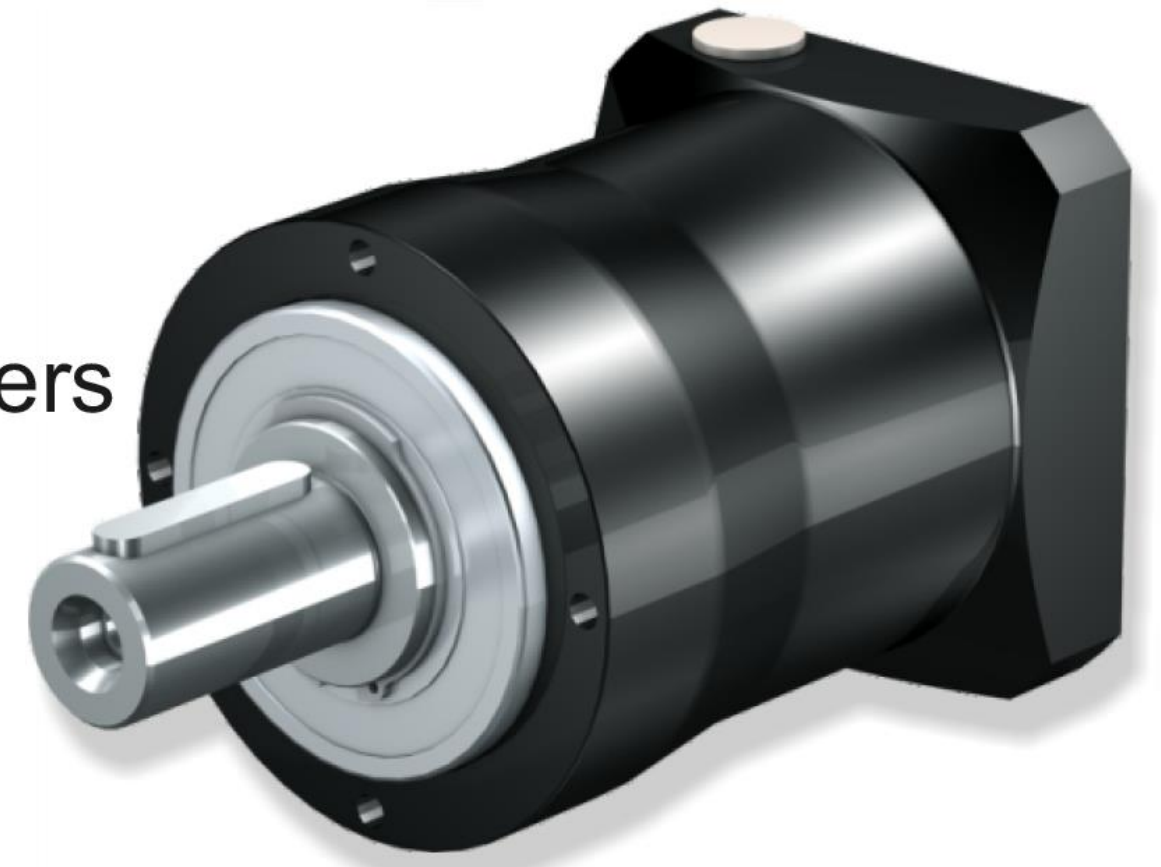

Technical Data :	
Full Load efficiency	95 %
Rated input speed	3000 min-1
Operating temperature	-25° ~ +90°
Maximum input speed	6000 min-1
Lubrication	Synthetic grease lubrication
Installation	arbitrary
Full load efficiency	95 %
Life expectancy	20000 H
Weight	3.7 Kg
Return clearance	& 1 t ; 3 arcmin
Return gap (economic type)	& 1 t ; 5 arcmin
Maximum allowable radial load	2400 N
Allow maximum axial load	2200 N
Maker size	∅19X 35/∅ 70X 3/4 - ∅6.5 - ∅90

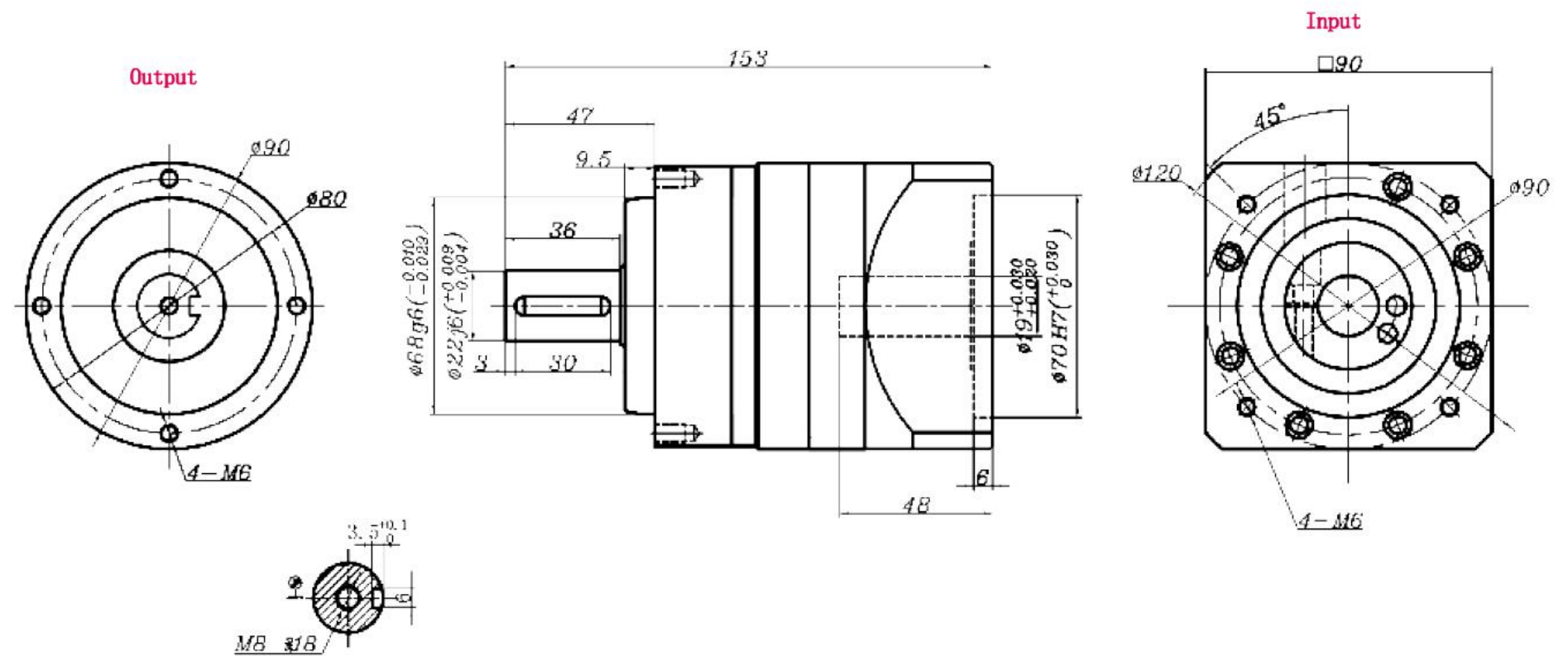

	3	4	5	7	10
Rate output torque	50 Nm	75Nm	75Nm	75Nm	50Nm
Fault stop torque	200Nm	250Nm	250Nm	250Nm	200Nm
Moment of inertia	1.2Kgcm <sup>2</sup>	0.95Kgcm <sup>2</sup>	0.86Kgcm <sup>2</sup>	0.79Kgcm <sup>2</sup>	0.75Kgcm <sup>2</sup>
Allow radial load	810 N	890N	960N	1100N	1200N
Allow axial load	930 N	1100N	1200N	1300N	1600N

Technical Data :	
Full Load efficiency	95 %
Rated input speed	3000 min-1
Operating temperature	-25° ~ +90°
Maximum input speed	6000 min-1
Lubrication	Synthetic grease lubrication
Installation	arbitrary
Full load efficiency	95 %
Life expectancy	20000 H
Weight	3.7 Kg
Return clearance	& 1 t ; 5 arcmin
Return gap (economic type)	& 1 t ; 7 arcmin
Maximum allowable radial load	2400 N
Allow maximum axial load	2200 N
Maker size	∅19X 35/∅ 70X 3/4 - ∅6.5 - ∅90

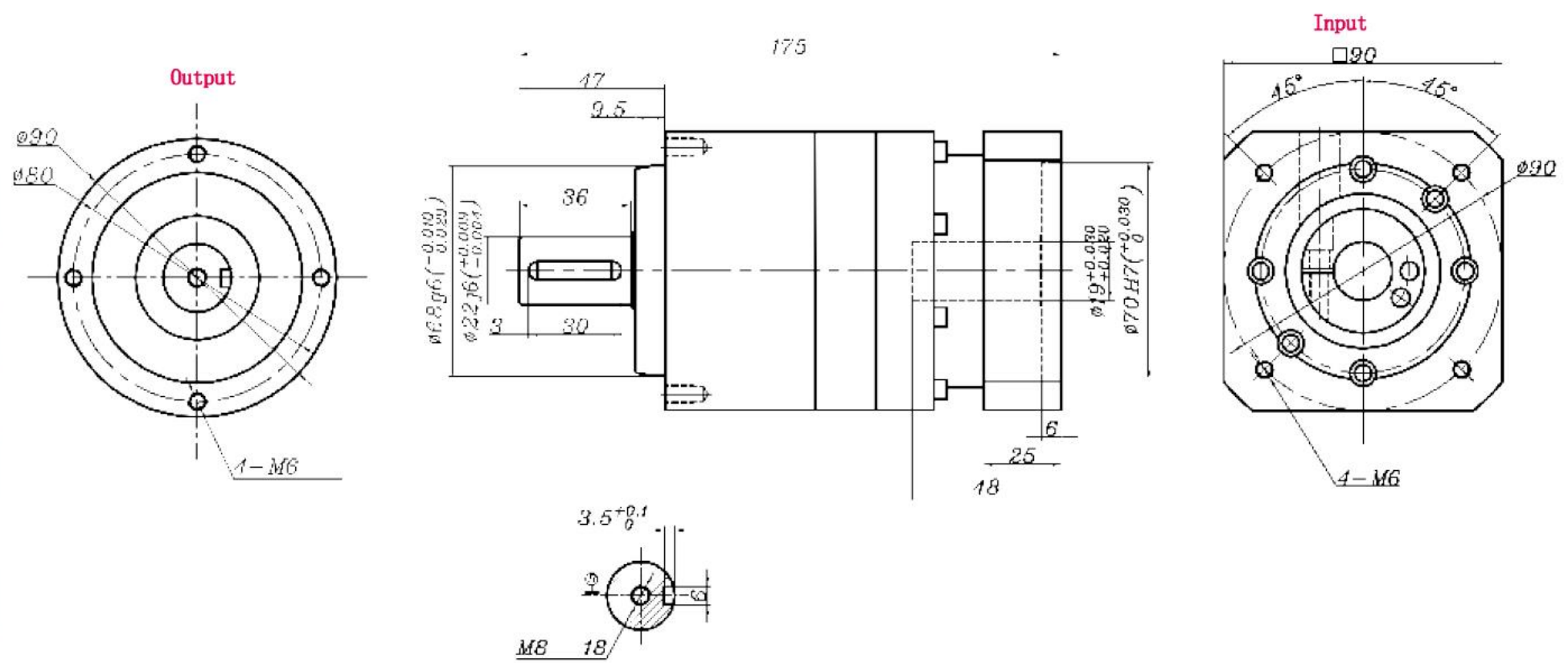

	15	16	20	25	28	30
Rate output torque	50 Nm	75Nm	75Nm	75Nm	75Nm	50Nm
Fault stop torque	200Nm	250Nm	250Nm	250Nm	250Nm	200Nm
Moment of inertia	0.72Kgcm <sup>2</sup>	0.74Kgcm <sup>2</sup>	0.72Kgcm <sup>2</sup>	0.71Kgcm <sup>2</sup>	0.73Kgcm <sup>2</sup>	0.70Kgcm <sup>2</sup>
Allow radial load	1400 N	1400N	1500N	1600N	1700N	1700N
Allow axial load	1900 N	1900N	2100N	2200N	2200N	2200N





## SE 120 Series [Single & Double Stage]

### Circular Flange Type Helical Planetary Reducers

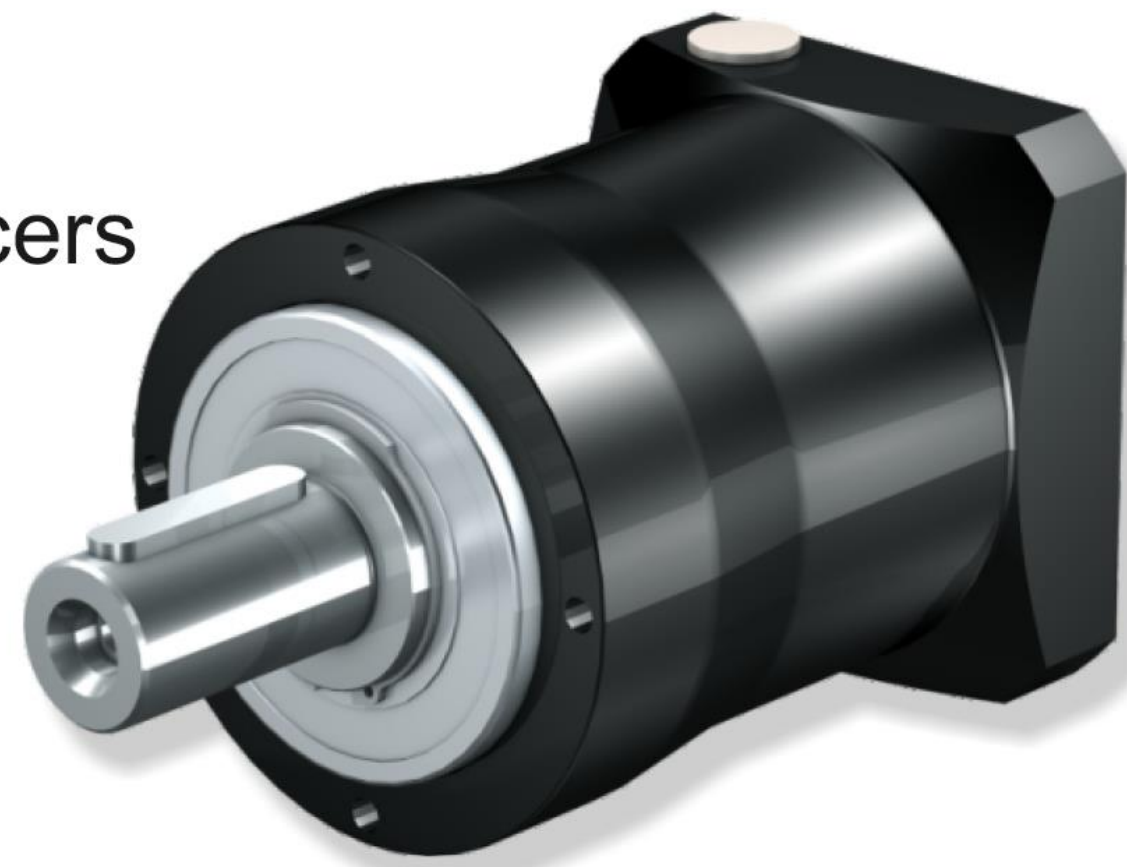

Technical Data :	
Rate output torque	120N
Rated input speed	3000 min <sup>-1</sup>
Operating temperature	-25° ~ +90°
Maximum input speed	6000 min <sup>-1</sup>
Lubrication	Synthetic grease lubrication
Installation	arbitrary
Full load efficiency	95 %
Life expectancy	20000 H
Weight	8 Kg
Return clearance	& 1 t ; 3 arcmin
Return gap (economic type)	& 1 t ; 5 arcmin
Permitted radial load	2000 N
Allow axial load	2500 N
Maker size	∅22x 55/ ∅ 110 x 8/4 -∅ 9 -∅145

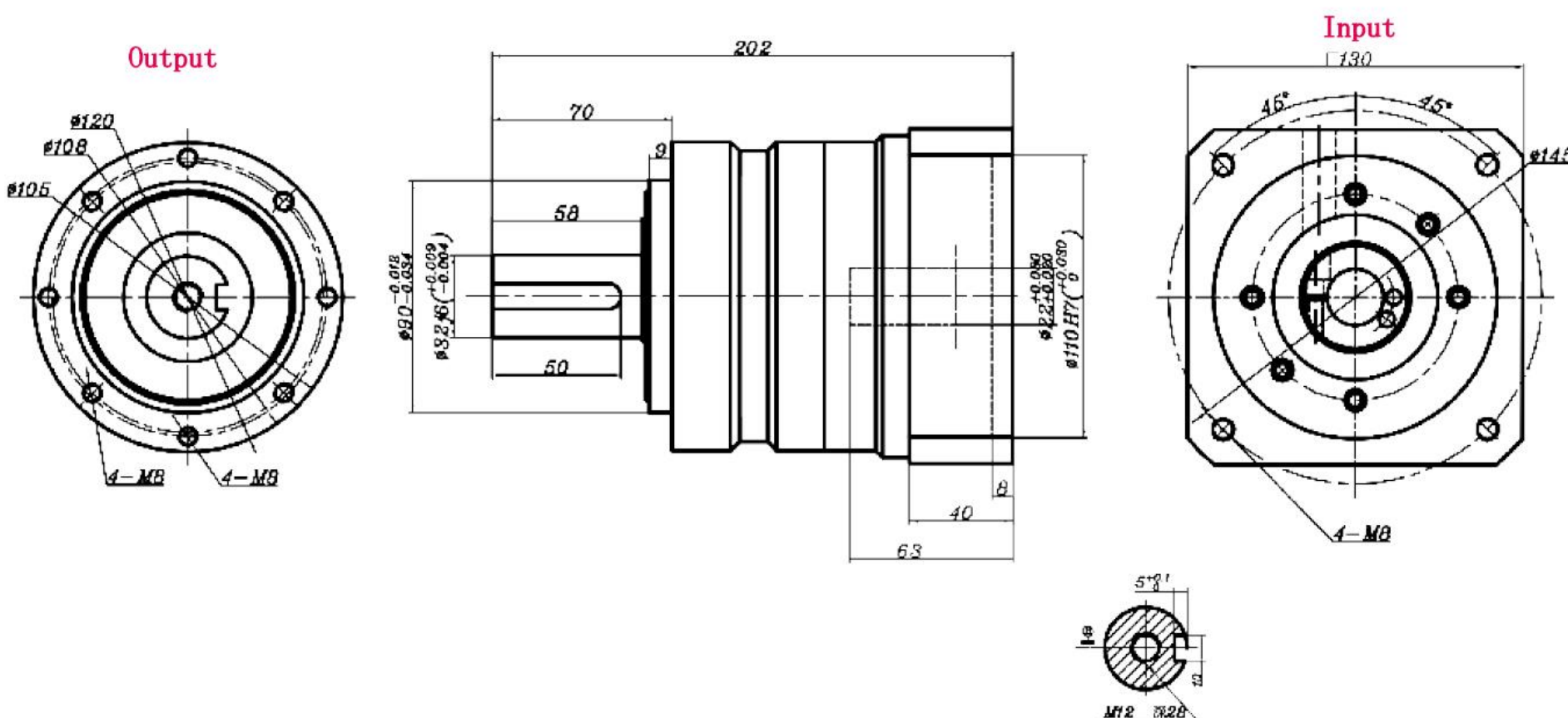

Technical Data :	
Rate output torque	180N
Rated input speed	3000 min <sup>-1</sup>
Operating temperature	-25° ~ +90°
Maximum input speed	6000 min <sup>-1</sup>
Lubrication	Synthetic grease lubrication
Installation	arbitrary
Full load efficiency	95 %
Life expectancy	20000 H
Weight	8.9Kg
Return clearance	& 1 t ; 5 arcmin
Return gap (economic type)	& 1 t ; 7 arcmin
Permitted radial load	2700 N
Allow axial load	3700 N
Maker size	∅22x 55/ ∅ 110 x 8/4 -∅ 9 -∅145

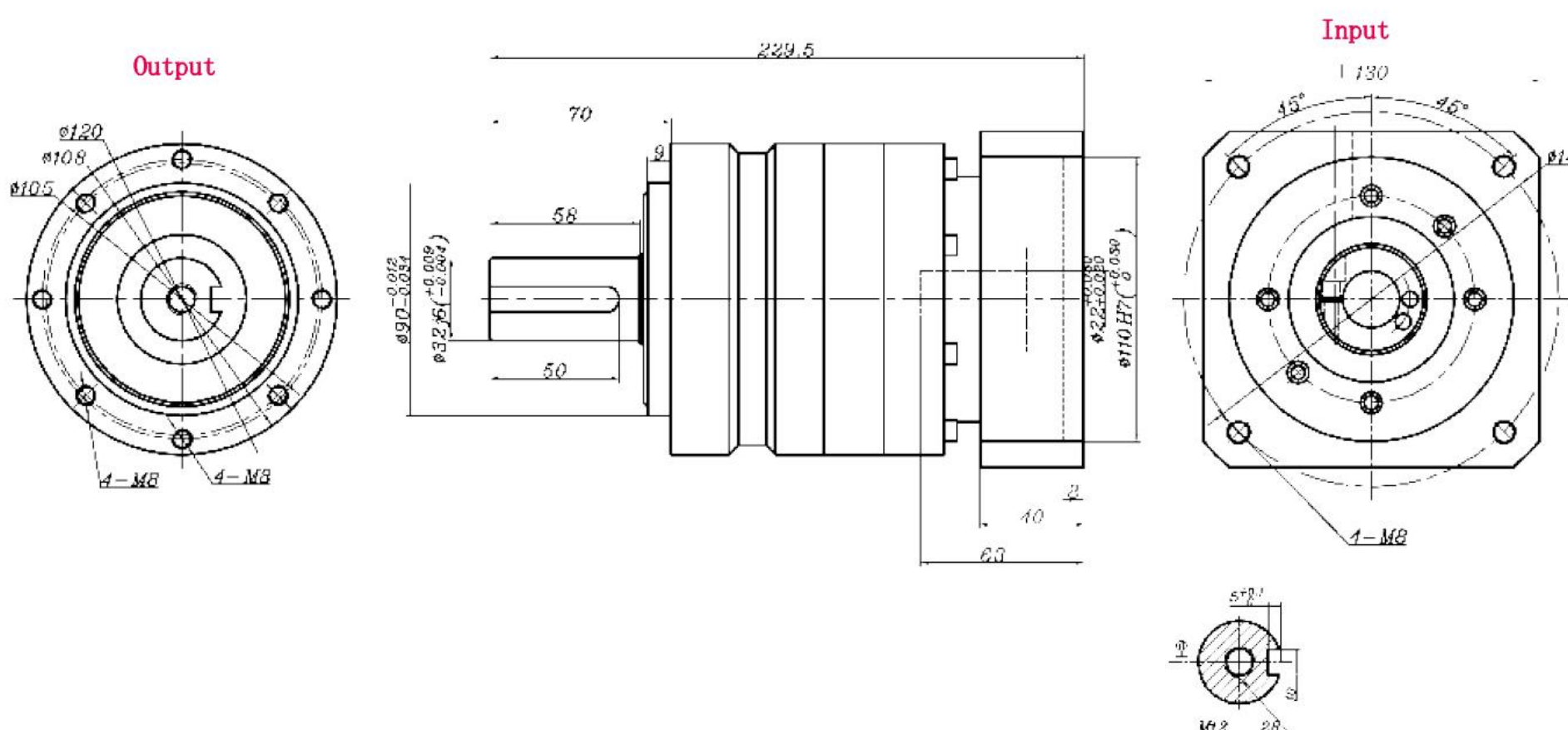



## 1.400W Brake

### Servo motor

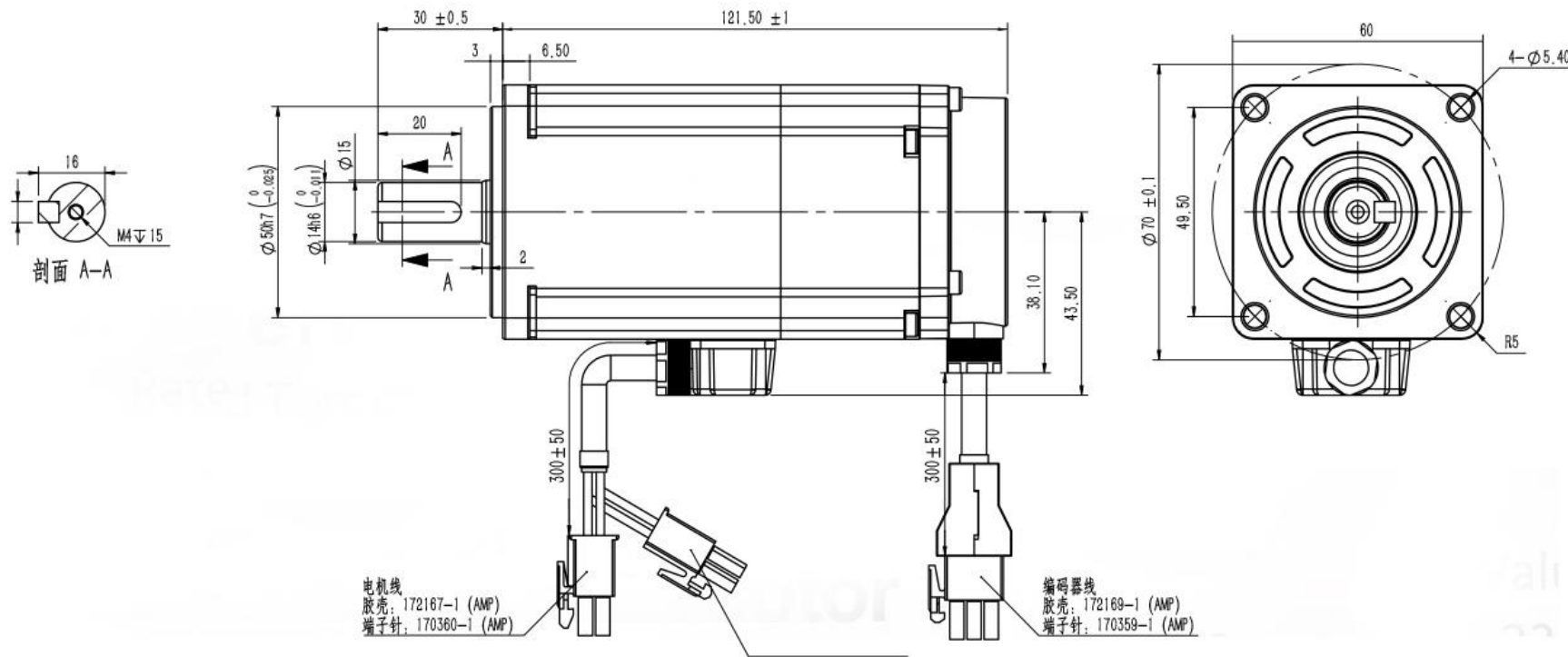

Motor Technical Specification					
Name	Value	Unit	Name	Value	Unit
Rated Power	400	W	Rated Voltage	220	V
Rated Speed	3000	RPM	Peak Speed	6000	RPM
Rated Current	2.5	Arms	Peak Current	7.5	Arms
Rated Torque	1.27	N.m	Peak Torque	3.81	N.m
Winding Resistance	2.6	$\Omega$	Winding Inductance	5.8	mH
Voltage Constant	30.9	V/1000r/min	Torque Coefficient	0.51	N.m/A
Rotor Inertia	0.5	$\text{Kg.m}^2 \times 10^{-4}$	Encoder	5 pairs of pole incremental encoder	
Braking Torque	1.5	N.m	Brake	With brake	

## 2.400W

### Servo motor

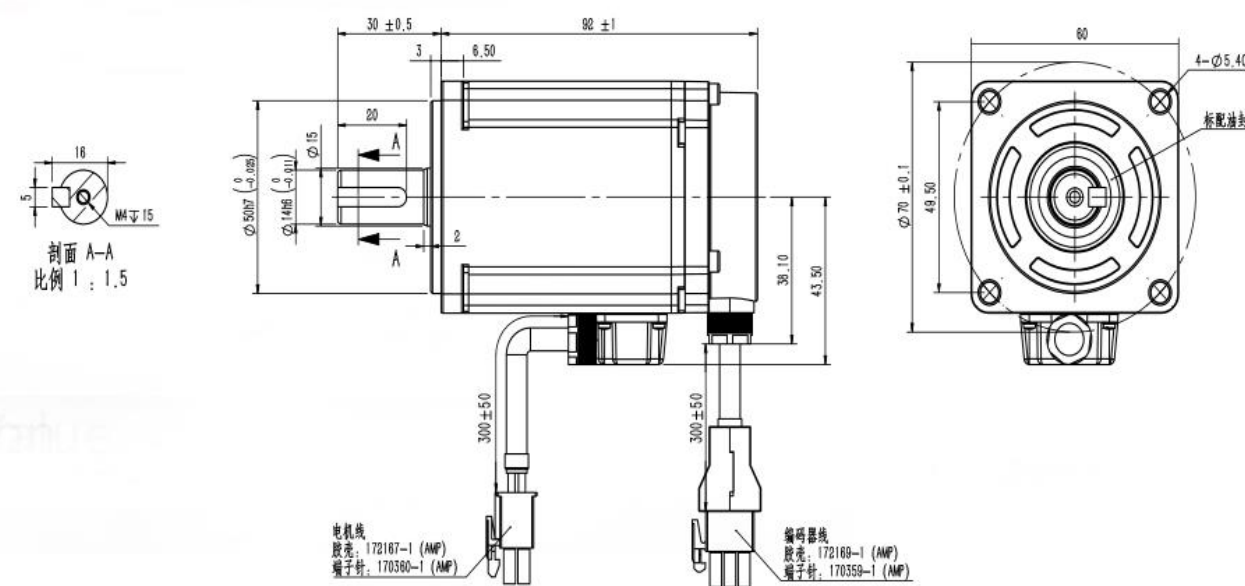

Motor Technical Specification					
Name	Value	Unit	Name	Value	Unit
Rated Power	400	W	Rated Voltage	220	V
Rated Speed	3000	RPM	Peak Speed	6000	RPM
Rated Current	2.5	Arms	Peak Current	7.5	Arms
Rated Torque	1.27	N.m	Peak Torque	3.81	N.m
Winding Resistance	2.6	$\Omega$	Winding Inductance	5.8	mH
Voltage Constant	30.9	V/1000r/min	Torque Coefficient	0.51	N.m/A
Rotor Inertia	0.45	$\text{Kg.m}^2 \times 10^{-4}$	Encoder	5 pairs of pole incremental encoder	









## 7.1kw 130mm Flange

**HQ MOTION Servo motor**

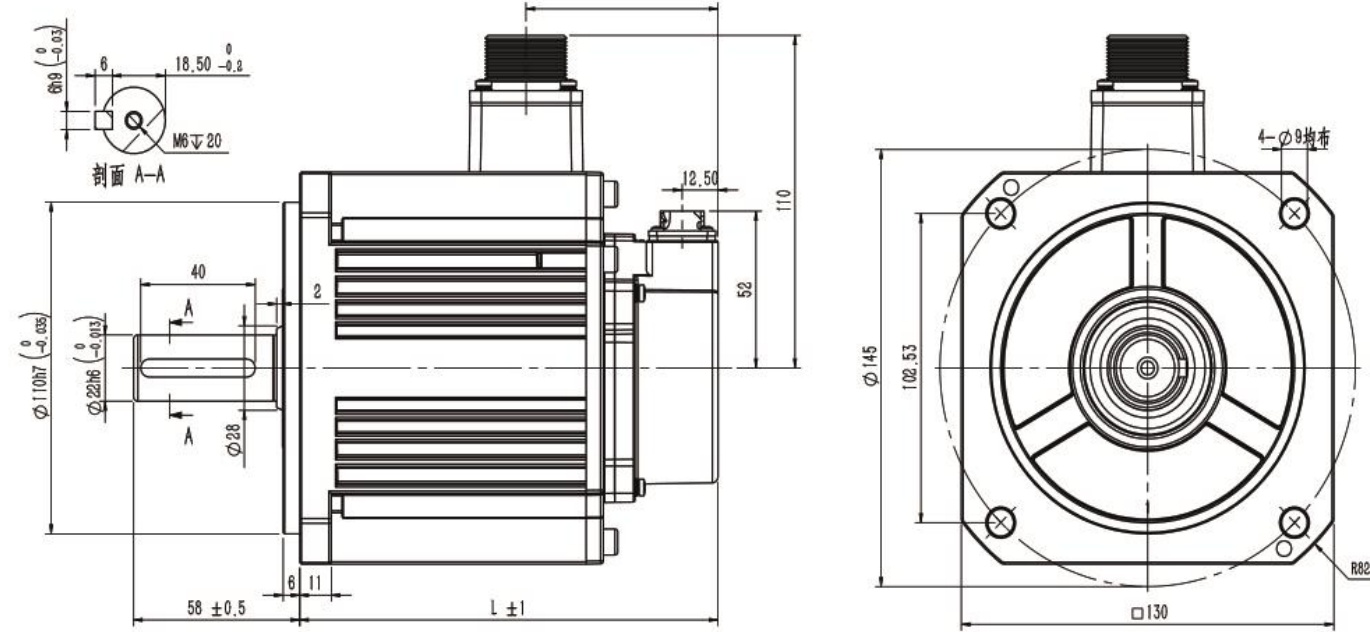

Motor Technical Specification					
Name	Value	Unit	Name	Value	Unit
Rated Power	1000	W	Rated Voltage	220	V
Rated Speed	2000	RPM	Peak Speed	3000	RPM
Rated Current	4.7	Arms	Peak Current	14.1	Arms
Rated Torque	4.77	N.m	Peak Torque	14.31	N.m
Winding Resistance	2.04	Ω	Winding Inductance	13.5	mH
Voltage Constant	66.2	V/1000r/min	Torque Coefficient	1.02	N.m/A
Rotor Inertia	9.3	Kg.m <sup>2</sup> x10 <sup>-4</sup>	Encoder	5 pairs of pole incremental encoder	
Braking Torque	/	N.m	Brake	/	

## 8.1kw with brake 130mm Flange

**HQ MOTION Servo motor**

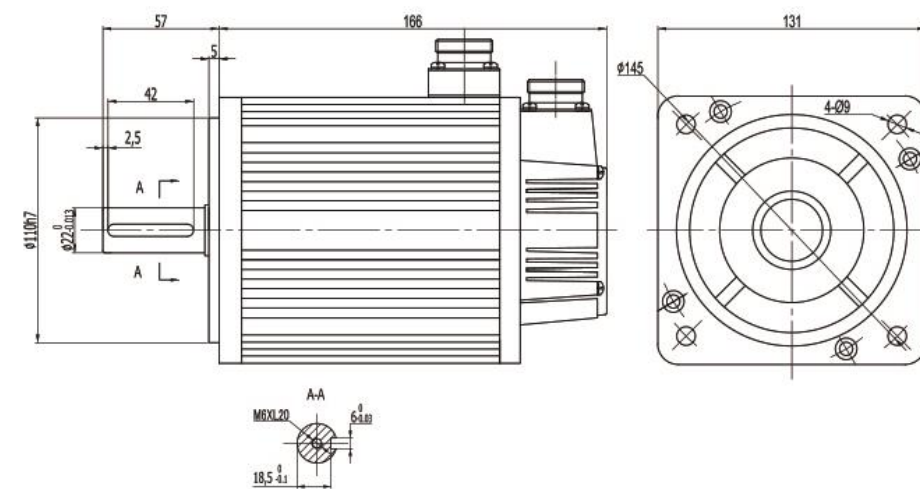

Motor Technical Specification					
Name	Value	Unit	Name	Value	Unit
Rated Power	1000	W	Rated Voltage	220	V
Rated Speed	2000	RPM	Peak Speed	3000	RPM
Rated Current	4.7	Arms	Peak Current	14.1	Arms
Rated Torque	4.77	N.m	Peak Torque	14.31	N.m
Winding Resistance	2.04	Ω	Winding Inductance	13.5	mH
Voltage Constant	66.2	V/1000r/min	Torque Coefficient	1.02	N.m/A
Rotor Inertia	11.5	Kg.m <sup>2</sup> x10 <sup>-4</sup>	Encoder	5 pairs of pole incremental encoder	
Braking Torque	15	N.m	Brake	With Brake	



## H300 SERIES HIGH PERFORMANCE VECTOR VFD



### FEATURES

- With advanced open loop vector control technology, and excellent voltage and current control technology;
- Starting Torque 0.5Hz/150%, speed ratio 1:100, dynamic response < 20ms, speed precision  $\pm 0.2\%$ ;
- Wide voltage range design, AC 3PH: 380V(-30%)~400V(+15%);
- Build-in Filter, with high EMC performance, which can work in the place with electromagnetic interference;
- Items below 22KW with build-in braking system;
- Support DC BUS mode and DC power supply;
- With various braking modes, such as dynamic braking, magnetic flux braking, and DC braking, it can stop at once;
- No stop with instant power failure, which meets various requirement of the customers;
- Designed air flue, support hanging, floor standing, flange installation modes.

### توضیحات

- سیستم پیشرفته Control Vector ، کنترل پیشرفته و حرفه ای ولتاژ و جریان
- شروع گشتاور ۱۵۰٪ در فرکانس ۵/ هر تیز، نسبت به سرعت ۱۰۰:۱، پاسخدهی پویا کمتر از ۲۰ میلی ثانیه ، دقت تنظیم سرعت در حدود  $\pm 0.2\%$
- طراحی وسیع در ولتاژ، سه فاز، AC 3PH: 380V(-30%)~400V(+15%)
- مدل‌های زیر ۲۲ کیلووات با سیستم ترمز داخلی تامین کننده حالت باس DC و منبع تغذیه DC
- انواع حالت ترمز، مثل ترمز دینامیک، مغناطیسی، ترمز DC که می تواند در لحظه متوقف کند.
- بدون توقف در قطعی لحظه ای برق، که برای مشتریان بسیار حائز اهمیت است.
- سیستم تهویه برای نصب به صورت آویزانی، قرارگیری روی کف و نصب از فلنج طراحی شده است.



# Terminal Wiring Diagram

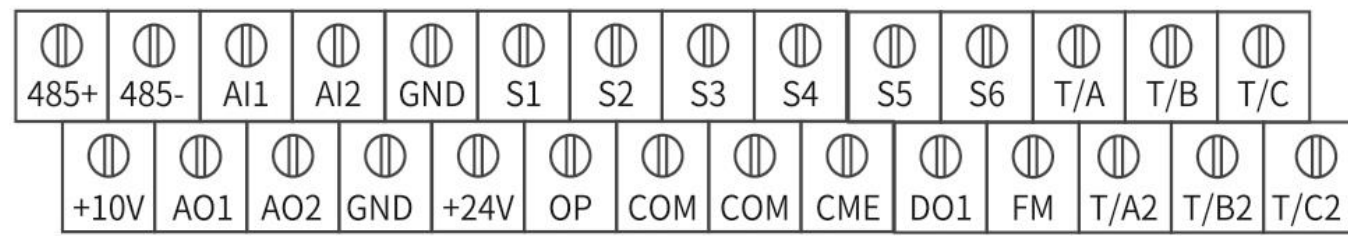

Terminal Mark	Name	Description
R、S、T	Three Phase Power Input Terminals	AC Input Three Phase Power Connection Point
(+)、(-)	DC Bus Positive and Negative Terminals	DC Bus Positive and Negative Terminals
(+)、PB	Common DC Bus Input Point(Connection Point of External Braking unit for above 11KW)	Connection Terminals of Braking Resistance
P、(+)	Connection Points of Braking Resistance Below 22KW	External Reactor Connection Terminals
U、V、W	External Reactor Connection Points	Connected to Three Phase Motor
⊕	Grounding Terminals	Grounding Terminals

Type	Terminal Mark	Terminal Name	Function Description
Power	+10V-GND	External +10V Power	Provide External +10V power,Max. Output Current:50mA. Generally used for external potentiometer working power,resistance range of potentiometer:1kΩ~5kΩ.
	+24V-COM	External +24V Power	Provide External +24V power,generally used for working power of digital input and output terminal and power of sensor. Max output current:200mA.
	OP	External Power Input Terminal	Connect via J9 wire in the controller board with +24V and COM,default connecting is with +24V. When using external signal driver digital input terminal S1~S6,OP needs to wire with external power and need to unplug J9 wire cap. J9 wire cap short circuit pin 1,2 to +24V,short circuit pin 2,3 connect with COM.
Analog Input	AI1-GND	Analog Input Terminal 1	1.Input voltage range:DC 0V~10V 2.Input Impedance:22kΩ
	AI2-GND	Analog Input Terminal 2	1.Input Range:DC 0V~10V/4mA~20mA 2.Input Impedance:for voltage input 22kΩ,for current input 500Ω. 3.J8 wire cap short circuit pin 2,2 with voltage input,short circuit pin 2,3 with current input.
Digital Input	S1-OP	Digital Input 1	1.Opto-isolator,compatible with bipolar input 2.Input Impedance:2.4kΩ 3.Voltage range for electric level input:9V~30V
	S2-OP	Digital Input 2	
	S3-OP	Digital Input 3	
	S4-OP	Digital Input 4	
	S5-OP	High Speed Pulse Input Terminals	With characters of digital input terminal, it can use as high speed pulse input channel also. Max input frequency:50kHz
Analog Output	AO1-GND	Analog Output 1	Defined by J5 wire connection in the controller board to have voltage or current output. Output Voltage range:0V~10V Output current range:0mA~20mA J5 wire cap short circuit Pin1,2 select voltage,short circuit pin 2,3 to select current.
	AO2-GND	Analog Output 2	Defined by J12 wire connection in the controller board to have voltage or current output. Output Voltage range:0V~10V Output current range:0mA~20mA J5 wire cap short circuit Pin1,2 select voltage,short circuit pin 2,3 to select current.
Digital Output	DO1-CME	Digital Output 1	Opto-isolator,bipolar open collector output Output voltage range:0V~10V Output Current range:0mA~20mA Note:Digital output Ground CME and digital input ground COM are internal isolated. Factory default do short circuit of CME and COM from J10 wire in the controller board(at that time DO! Default driver by +24V).If DO1 needs to drive by exer
	FM-CME	High Frequency Pulse Output	With the restriction of F6-00" FM Terminal Output Mode Selection".The max frequency is 50kHz when working as a high speed pulse;same standard as DO1 when working as a collector open circuit.
Relay Output	T/A-T/B	Normally Close Terminals	Contact point Driver ability: AC250V,3A,COSØ=0.4. DC 30V,1A.
	T/A-T/C	Normally Open Terminals	
	T/A2-T/B2	Normally Close Terminals	
	T/A2-T/C2	Normally Open Terminals	
Communication	485+485-	RS485 Communication Terminals	RS485 communication,short circuit pin 1,2 of J14,it can match 100R terminal resistance.

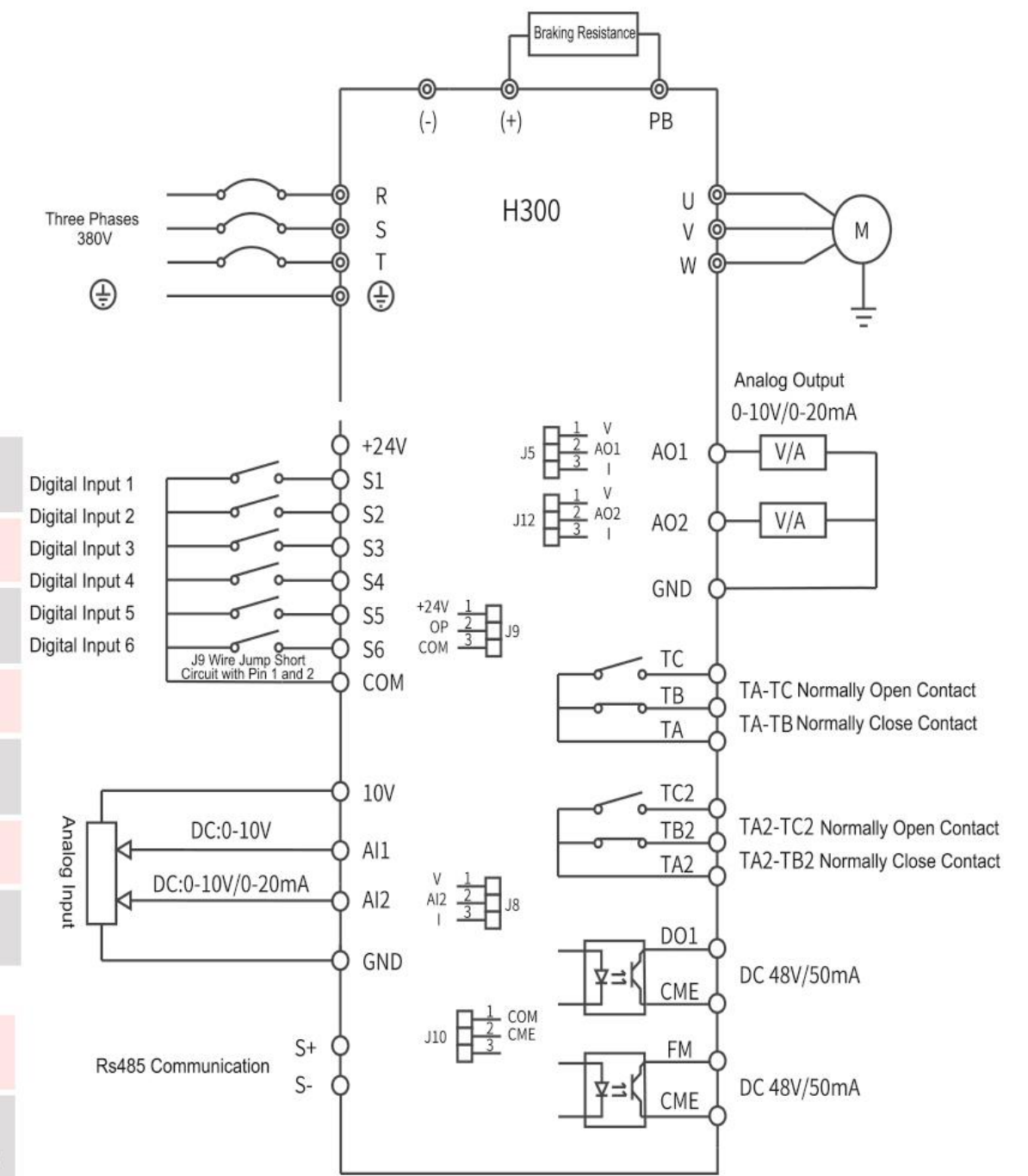

# Terminal Wiring Diagram



## Spindle motor ▶

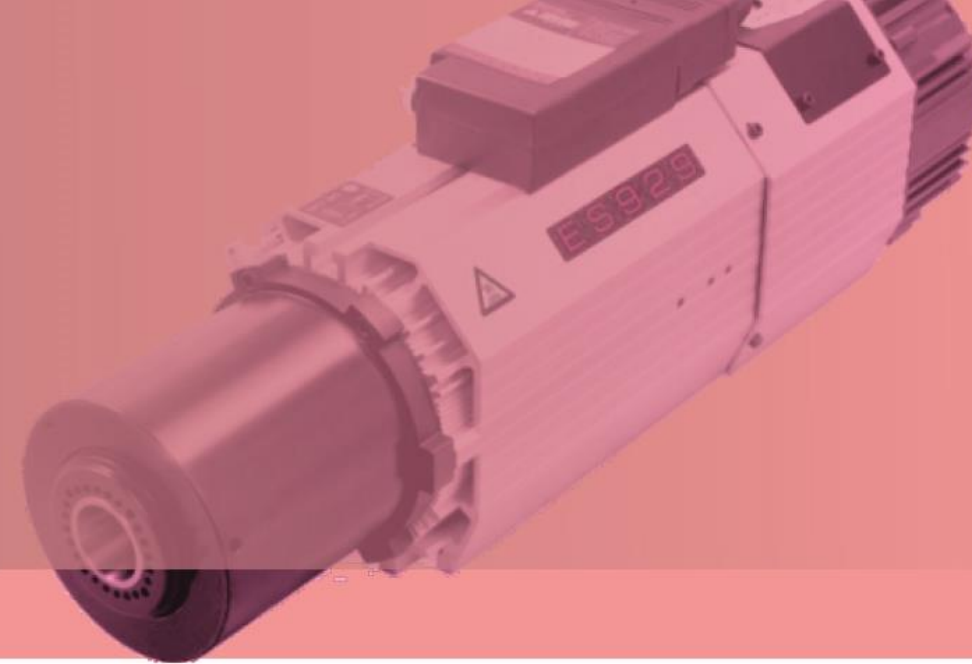

سرعت چرخش	: 18000RPM
توان	: 4.5KW
گشتاور	: 2.39Nm
ولتاژ	: 380V
جریان	: 15/9.0A
فرکانس	: 300HZ
قطر شفت خروجی	: ER 32- $\Phi$ 3.175- $\Phi$ 20
سیستم خنک کاری	هوا
شماره بلبرینگ	.: 2*7008C P4,2*7002C P4
وزن	: 12Kg



سرعت چرخش	: 24000RPM
توان	: 9KW
ولتاژ	: 380V
جریان	: 20/32A
فرکانس	: 400 -800HZ
اتصال شفت اسپیندل	: ISO30cone
سیستم خنک کاری	هوا
شماره بلبرینگ ها	.: 2*7008C/P4,2*7006X/P4
وزن	: 31Kg





## Full-automatic lubricating oil pump 2Liter



TYPE:	hts02	TANK VOLUME	2L
VOLTAGE:	220V	MOTOR POWER:	28W
ELECTRIC CURRENT:	0.35A	RATED PRESSURE:	1MPa
FLOW RATE	50ML/MIN	GREASE LABEL	32#-64#
SINGLE WORKFLOW	0-99ML	INTERVAL	10-999MINS

## Semi-automatic lubricating oil pump 1.8Liter



TYPE:	hts02-d	TANK VOLUME	1.8L
VOLTAGE:	220V	MOTOR POWER:	28W
ELECTRIC CURRENT:	0.35A	RATED PRESSURE:	1MPa
FLOW RATE	50ML/MIN	GREASE LABEL	32#-64#



# Helical & Straight Racks

## Helical Hardened Racks

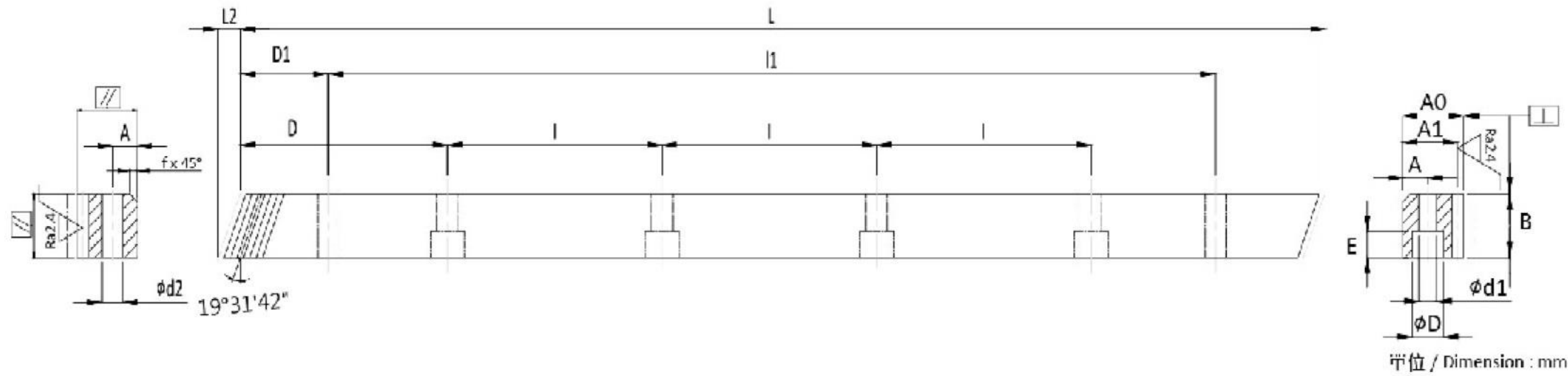

Code	Module	L	L2	No. of Teeth	B	A0	A1	D	I	No of Holes	A	φd1	φD	E	D1	I1	φd2	f	F <sub>ta</sub> kN	KG
CHTMH01510-DIN10	1.5	1000	6.00	200	17	17	15.5	62.5	125	8	7	6	9.5	7	31.7	936.6	5.7	1.5	4.57	2.1
CHTMH02010-DIN10	2	1000	8.50	150	24	24	22	62.5	125	8	8	7	11	7	31.7	936.6	5.7	2	8.56	4.1
CHTMH02020-DIN10	2	2000	8.50	300	24	24	22	62.5	125	16	8	7	11	7	31.7	1936.6	5.7	2	8.66	8.2

جنس Material S45C  
 زاویه Right Hand Angle 19 31 42"  
 سختی Hardness: HRC 50~55  
 سطح Surfaces: Sand-blasted.

## Straight Milled Racks

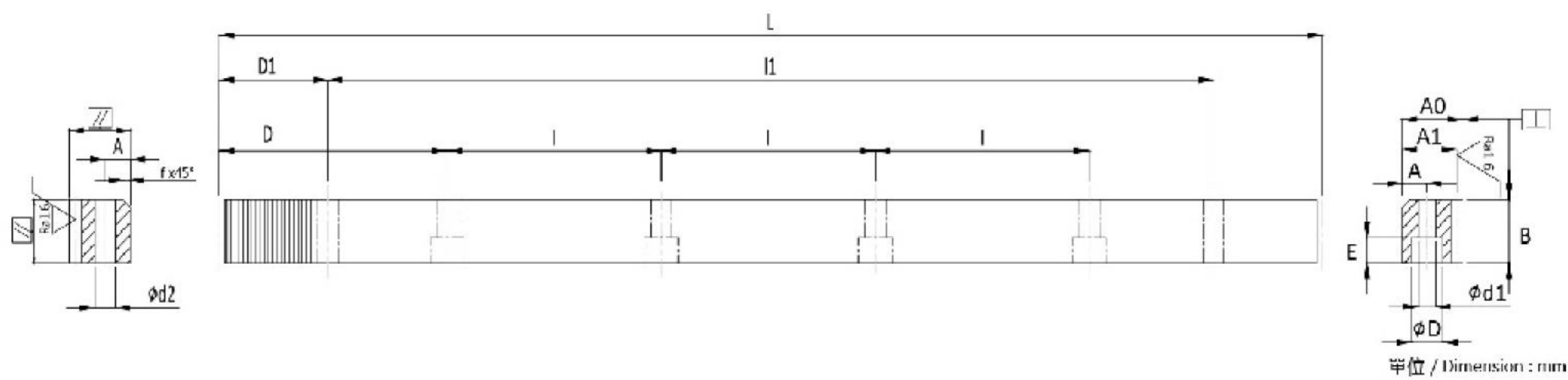

Code	Module	L	No. of Teeth	B	A0	A1	D	I	No of Holes	A	φd1	φD	E	D1	I1	φd2	f	F <sub>ta</sub> kN	KG
CSTM01510-DIN8	1.5	999.03	212	17	17	15.5	62.44	124.88	8	7	6	9.5	7	29	941.00	5.7	1.5	3.62	1.9
CSTM02010-DIN8	2	1005.31	160	25	24	22	62.83	125.66	8	8	7	11	7	31.3	942.70	5.7	2	7.07	4.1
CSTM02020-DIN8	2	2010.62	320	25	24	22	62.83	125.66	16	8	7	11	7	31.3	1948.00	5.7	2	7.15	8.1
CSTM03010-DIN8	3	1017.88	108	30	29	26	63.62	127.23	8	9	10	15	9	34.4	949.10	7.7	2	12.61	5.9
CSTM03020-DIN8	3	2035.75	216	30	29	26	63.62	127.23	16	9	10	15	9	34.4	1967.00	7.7	2	12.80	11.9
CSTM04010-DIN8	4	1005.31	80	40	39	35	62.83	125.66	8	12	10	15	9	37.5	930.30	7.7	2	22.21	10.5
CSTM04020-DIN8	4	2010.62	160	40	39	35	62.83	125.66	16	12	10	15	9	37.5	1935.60	7.7	2	22.63	21.0

جنس Material S45C  
 سختی Hardness: HRC 10~12



## 57HSxx Series

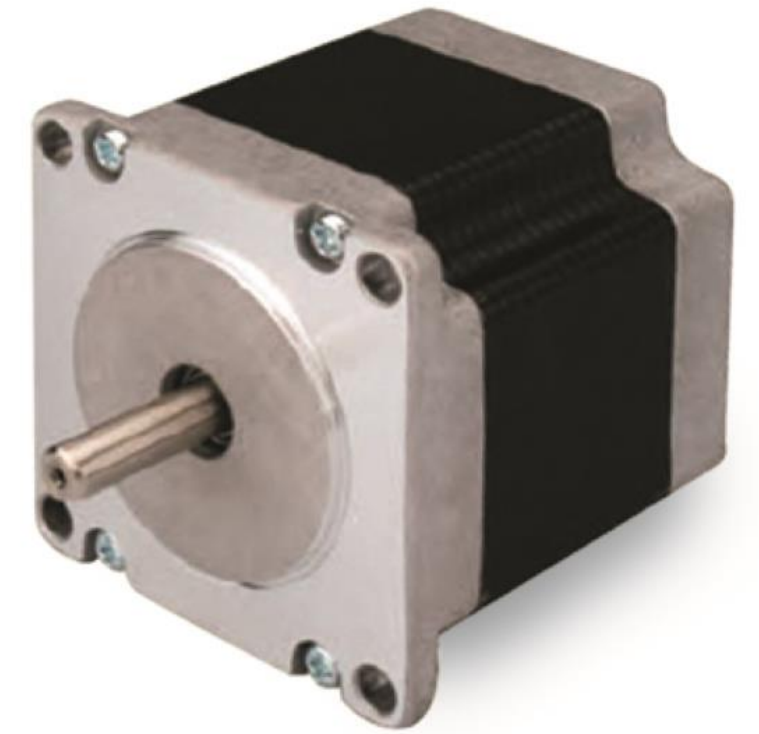
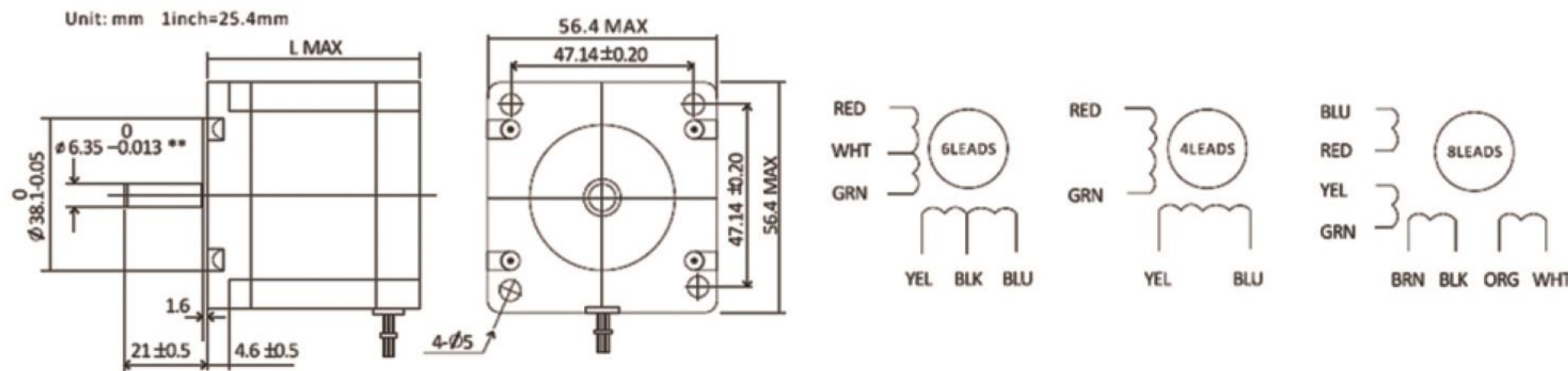

The Diameter of the shaft the 57HS22 is 8 mm, and those of other are 6.35 mm

### Match Drives

Model	Match Drives	Model	Match Drives
57HS04	EM503 / EM705 / DM556	57HS13	EM503 / EM705 / DM556
57HS09		57HS22	

### General Specifications

Angle Accuracy	± 5% (full step, no load)
Temperature Rise	80°C Max
Ambient Temperature	-10°C - +50°C
Insulation Resistance	100M Ω min. 500VDC
Dielectric Strength	500VAC for one minute
Shaft Radial Play	0.06 Max. (450g-load)
Shaft Axial Play	0.08 Max. (450g-load)

### Selection Table

phase	NEMA Size	Model	Step Angle	# of Conection Leads	Current / phase (A)	Holding Torque (Nm)	Length L (mm)	Weight (Kg)	Match Drives	
2	23	57HS04	1.8	6	Series	2.0	0.4	41	0.45	EM503/DM556
					Unipolar	2.8	0.28			
					Parellel	4.2	1.3			
		57HS09	1.8	8	Series	2.1	1.3	54	0.6	EM503/Em705/DM556
					Unipolar	2.8	0.9			
					Parellel	4.0	1.8			
		57HS13	1.8	8	Series	2.0	1.8	76	1.0	EM503/Em705/DM556
					Unipolar	2.8	1.3			
					Parellel	5.6	2.2			
		57HS22	1.8	8	Series	2.8	2.2	81	1.15	EM503/Em705/DM556
					Unipolar	4.0	1.5			
					Parellel	5.6	2.2			

**Stepper** ▶ A stepper motor or step motor or stepping motor is a brushless DC electric motor that divides a full rotation into a number of equal steps.





## 86HSxx Series

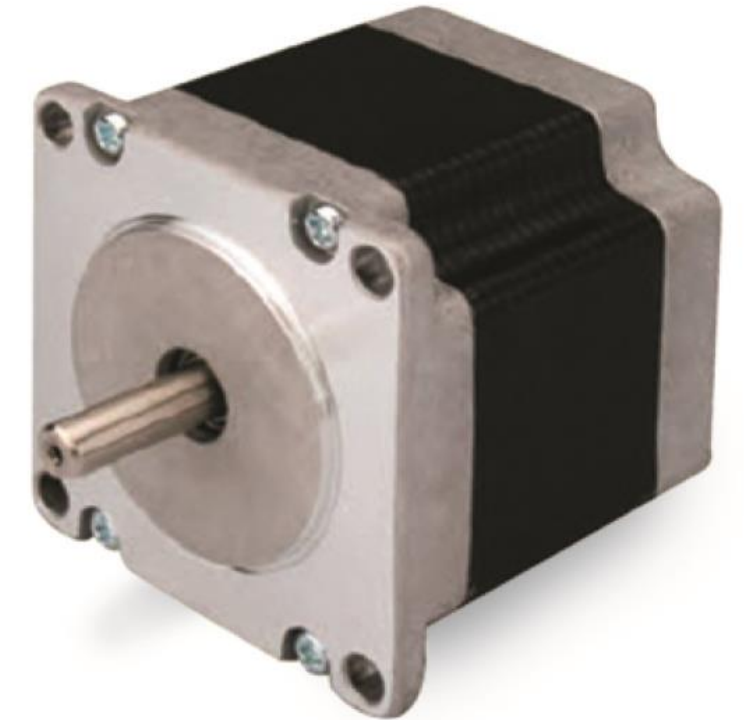
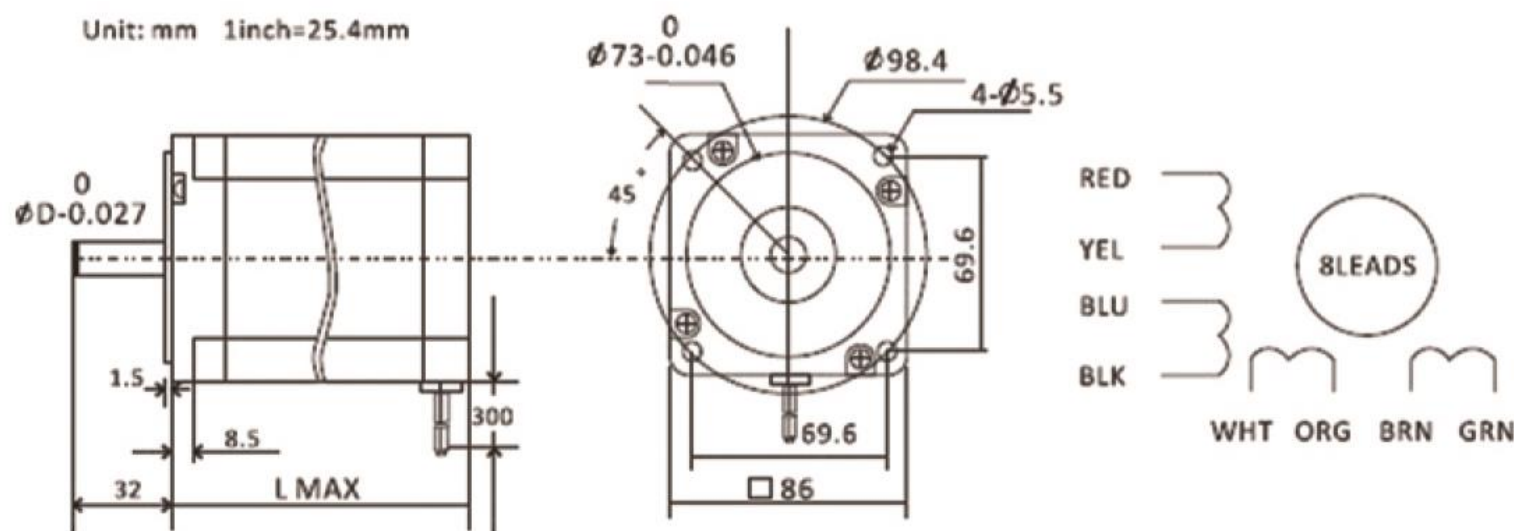

The shaft of the 86HS45 is round, no flat.

### Match Drives

Model	Match Drives	Model	Match Drives
86HS35	EM705 / EM806 / DM1182	86HS85/86HS120	EM705 / EM806 / DM1182
86HS45/86HS65			

### General Specifications

Angle Accuracy	± 5% (full step, no load)
Temperature Rise	80°C Max
Ambient Temperature	-10°C - +50°C
Insulation Resistance	100M $\Omega$ min. 500VDC
Dielectric Strength	500VAC for one minute
Shaft Radial Play	0.06 Max. (450g-load)
Shaft Axial Play	0.08 Max. (450g-load)

### General Specifications

Model	T	KEY	D
86HS35	/	/	9.5
86HS45	/	/	12.7
86HS65, 86HS85	14.7	5*5*25	12.7
86HS120	17.875	5*5*25	15.875

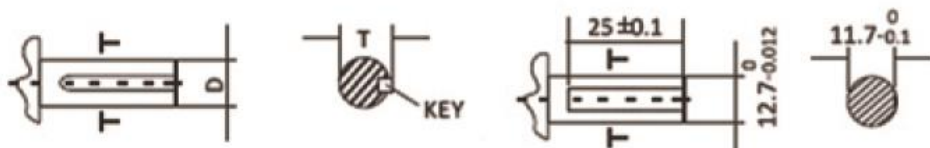

### Selection Table

phase	NEMA Size	Model	Step Angle	# of Connection Leads	Current / phase (A)	Holding Torque (Nm)	Length L (mm)	Weight (Kg)	Match Drives	
2	34	86HS35	1.8	6	Parellel	4.0	3.5	65	1.7	EM705/EM806/DM870
					Series	2.0	3.5			
					Unipolar	2.8	2.5			
		86HS45	1.8	8	Parellel	6.0	4.5	80	2.3	EM705/EM806/DM870/DM1182
					Series	3.0	4.5			
					Unipolar	4.2	3.2			
		86HS65	1.8	8	Parellel	6.1	6.5	96	2.3	EM806/DM870/DM1182/DM2282
					Series	3.05	6.5			
					Unipolar	4.3	4.6			
		86HS85	1.8	8	Parellel	6.8	8.5	118	3.8	EM806/DM870/DM1182/DM2282
					Series	3.4	8.5			
					Unipolar	4.9	6.0			
86HS120	1.8	8	Parellel	6.0	12	156	5.3	EM806/DM870/DM1182/DM2282		
			Series	3.0	12					
			Unipolar	4.2	8.4					

## Stepper Drive



Model	Phase	Series	Control Type	Power			Matching Motors (NEMA)	Configuration	Connector Type
				Voltage (v)		Current (A)			
				AC	DC				
M542	2	M	Step & Dir	-	24 - 50	1.0 - 4.2	17, 23	DIP switch	X
M752	2	M	Step & Dir	-	20 - 70	1.26 - 5.2	23, 34	DIP switch	X
M860	2	M	Step & Dir	-	24 - 80	2.4 - 7.2	17, 23, 34	DIP switch	X
M880A	2	M	Step & Dir	-	24 - 80	2.8 - 7.8	23, 34	DIP switch	X
MA860H	2	M	Step & Dir	36 - 80	50 - 110	2.4 - 7.2	34, 42	DIP switch	X



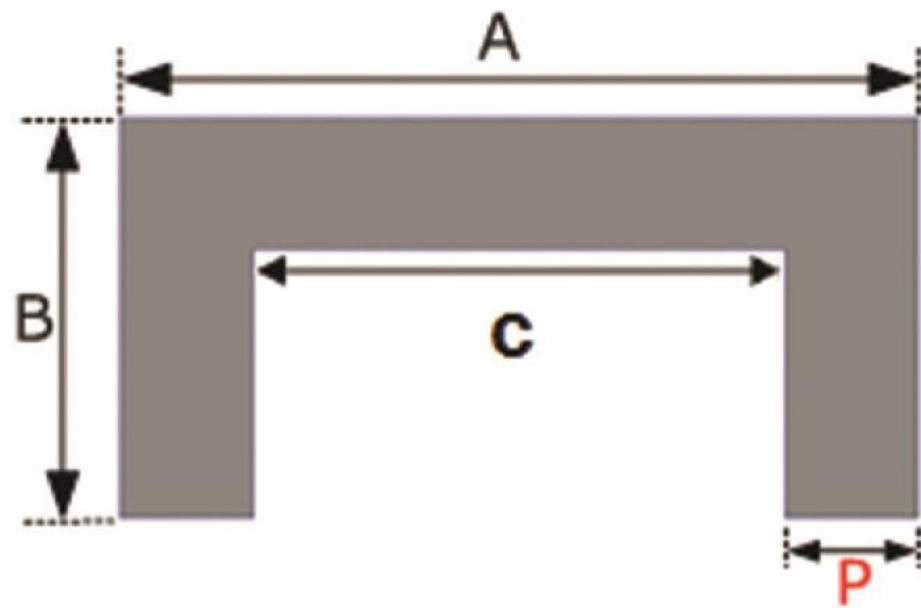

## Axis Cover ▶

Size no.	A [mm]	B [mm]	C [mm]	P [mm]
100	140	100	100	20
120	160	100	120	20
200	240	100	200	20
320	360	100	320	20
500	540	100	500	20
160	200	100	160	20
260	300	100	260	20
400	440	100	400	20

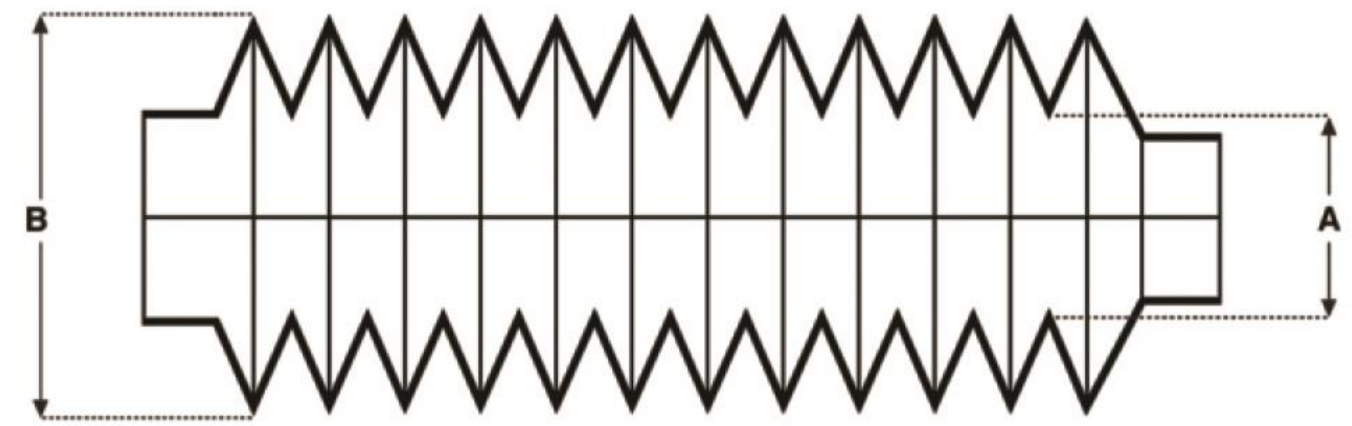

## Ball Screw Cover ▶

Size no.	A [mm]	B [mm]
25	25	35
30	30	40
35	35	45
45	45	55
55	55	65

### Standard Cover Width & Height

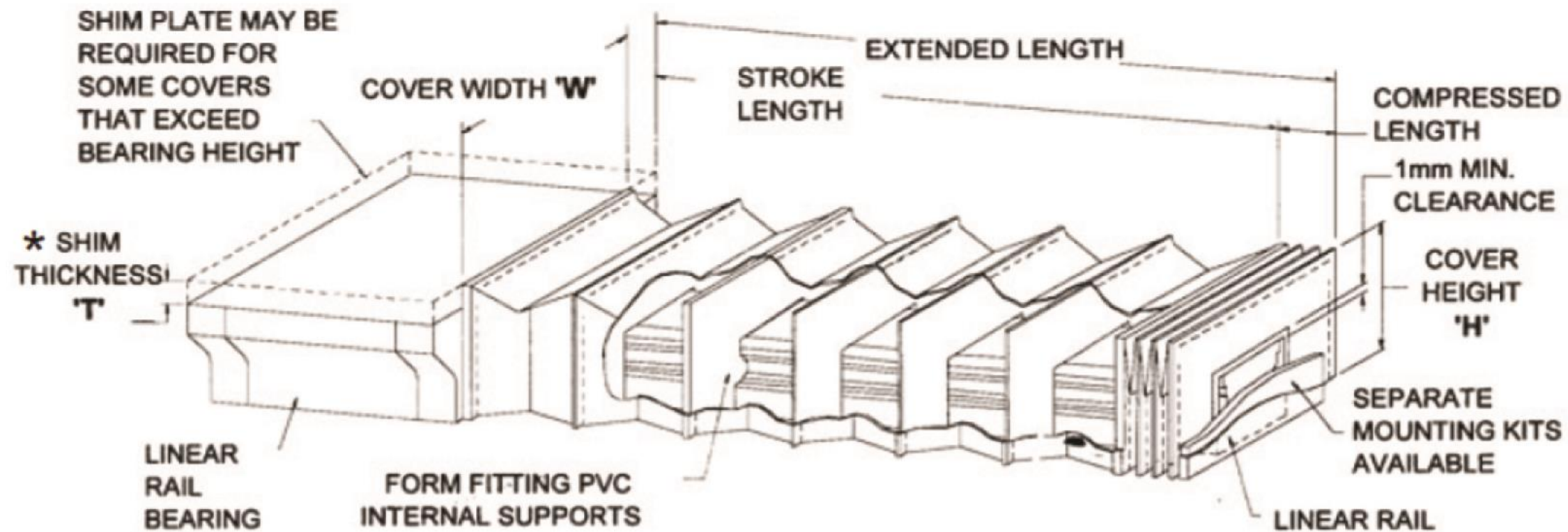

## Rail Cover ▶

Rail Size	W	H
15	59	33
20	64	34
25	67	39
30	72	43
35	78	45
45	89	51

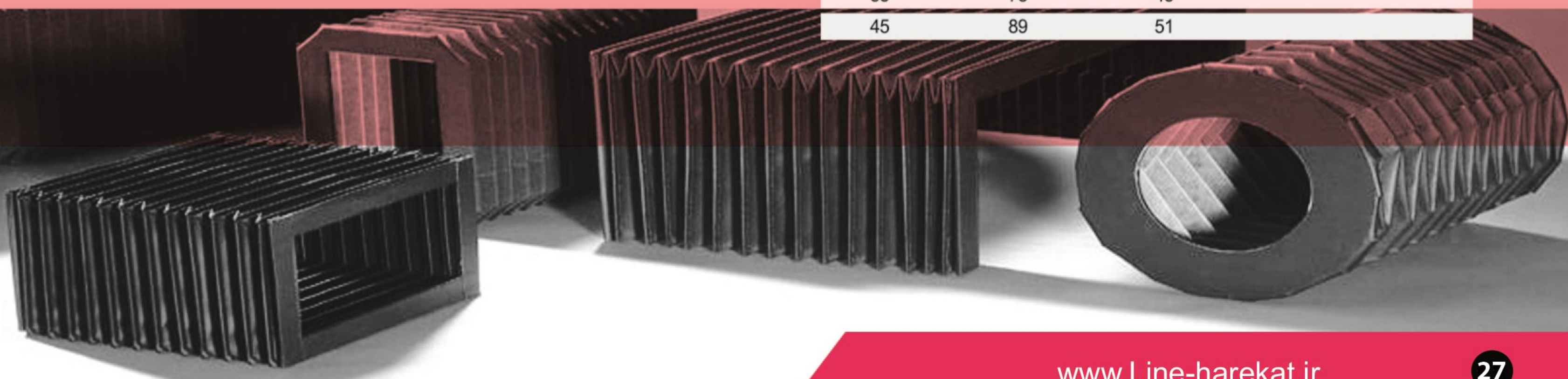



## Ball Transfer Units ▶

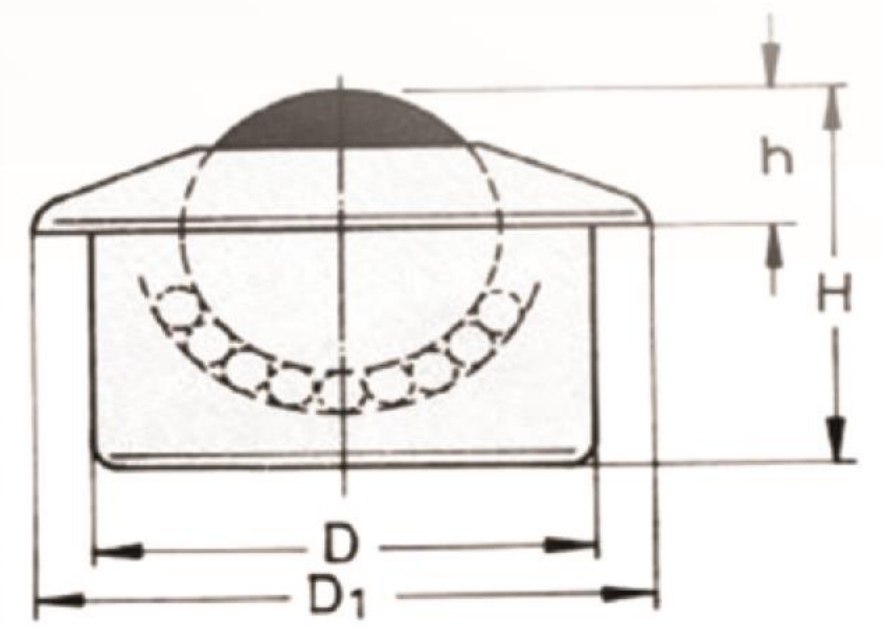
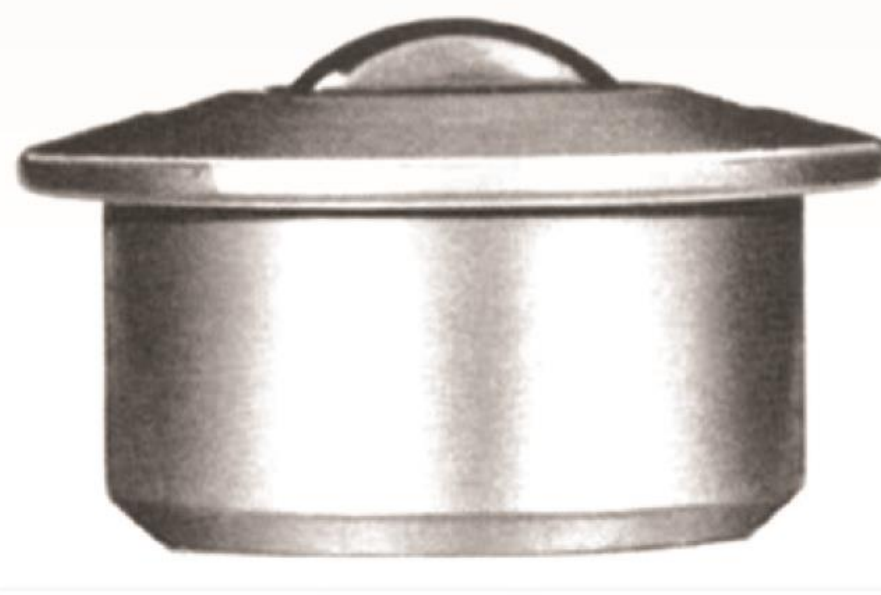
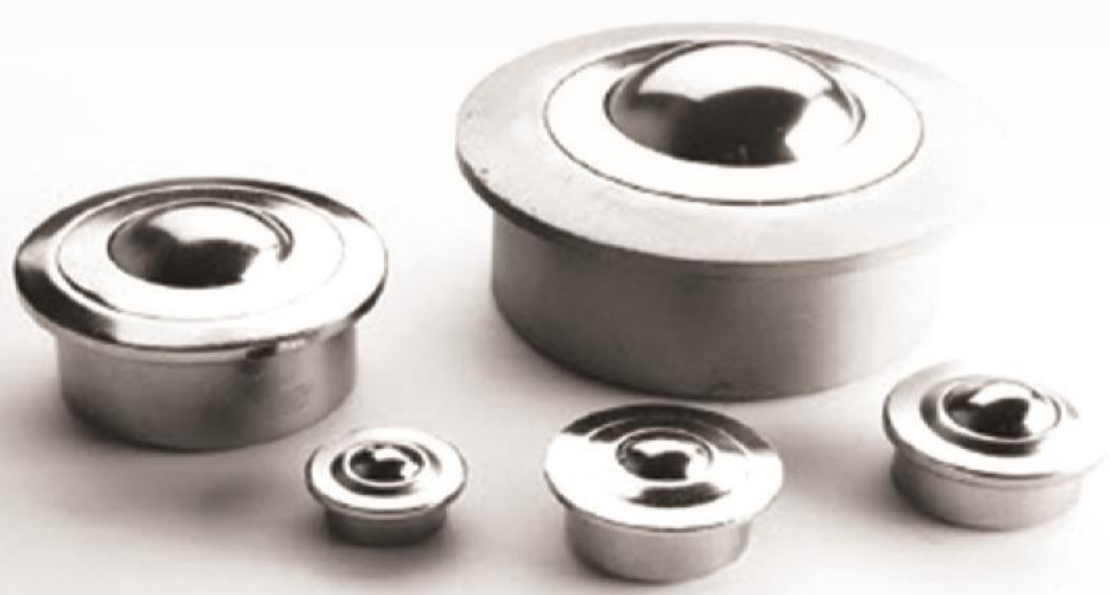

Part No.	Ball Size [mm]	D [mm]	D1 [mm]	h [mm]	H [mm]
SP 12 B	12.7	22	--	5.5	16.5
SP 15 B	15.8	24	31.5	10	21
SP 22 B	22.2	36	45	9.8	30.5
SP 25 B	25.4	38	45	13.5	31
SP 30 B	30	45	55	14	36.8
SP 45 B	44.4	62	75	19	53.5
SP 60 B	60	100	117	48	77

Part No.	Match Nuts	D	B	H	h	E	L	C1	C2	P	X	W	Y
BSG 16 H	1605/1610	28	52	40	20	12	40	8	24	40	M5	38	M6
BSG 1616	1616	32	54	38	19	8	40	8	24	44	M5	42	M6
BSG 20 H	2005 / 2010	36	62	44	22	12	40	8	24	48	M6	47	M6
BSG 2020	2020	39	64	46	23	11	40	8	24	52	M6	50	M6
BSG 25 H	2505 / 2510	40	66	48	24	13	40	8	24	50	M6	51	M6
BSG 2525	2525	47	68	56	28	9	40	8	24	50	M6	60	M6
BSG 32 H	3205 / 3210	50	86	62	31	17	40	8	24	66	M8	65	M6
BSG 40 H	4005 / 4010	63	100	70	35	19	40	8	24	80	M8	78	M6
BSG 50 H	5010	75	116	85	42.5	22	46	10	26	92	M8	93	M6

## Support Nut ▶

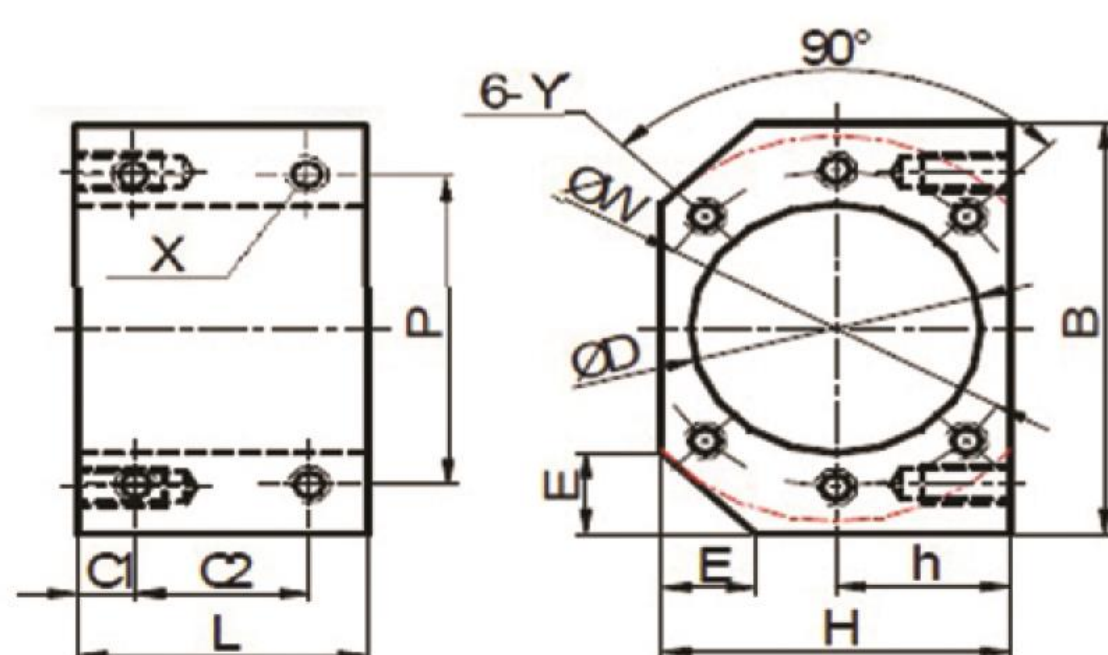



# Support Units

## BK Series

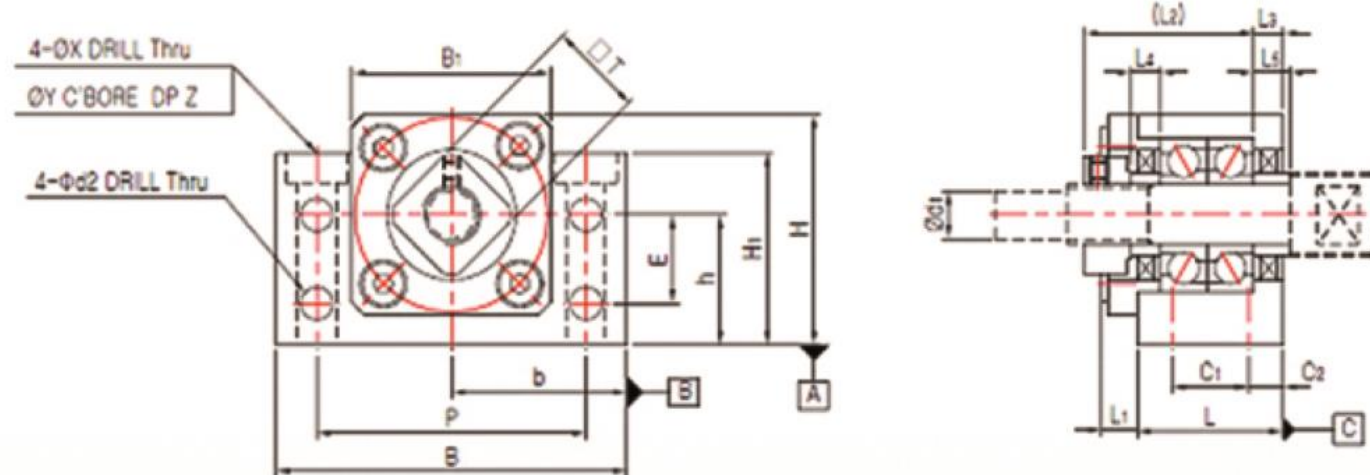

BK 10~40

Model No.	d <sub>1</sub>	L	L <sub>1</sub>	L <sub>2</sub>	L <sub>3</sub>	B	H	b±0.02	h±0.02	B <sub>1</sub>	H <sub>1</sub>	E	P	C <sub>1</sub>	C <sub>2</sub>	d <sub>2</sub>	X	Y	Z	Collar Size		□T	Mess(g)	
																					L <sub>4</sub>	L <sub>5</sub>		
BK6	6	23	5	24	4	52	32	26	17	25	26	-	38	-	11.5	-	6.6	11	6	5	5	12	230	
BK8	8	23	7	26	4	52	32	26	17	25	26	-	38	-	11.5	-	6.6	11	6	5.5	7.5	14	230	
BK10	10	25	5	29	5	60	39	30	22	34	32.5	15	46	13	6	5.5	6.6	10.8	5	5	5	16	360	
BK12	12	25	5	29	5	60	43	30	25	34	35	18	46	13	6	5.5	6.6	10.8	6	5	5	19	390	
BK15	15	27	6	32	6	70	48	35	28	40	38	18	54	15	6	5.5	6.6	10.8	6	6	6	22	530	
BK17	17	35	9	44	7	86	64	43	39	50	55	28	68	19	8	6.6	9	14	8.5	7	7	24	1270	
BK20	20	35	8	43	8	88	60	44	34	52	50	22	70	19	8	6.6	9	14	8.5	8	8	30	1650	
BK25	25	42	12	54	9	106	80	53	48	64	70	33	85	22	10	9	11	17.5	11	9	9	35	2310	
BK30	30	45	14	61	9	128	89	64	51	76	78	33	102	23	11	11	14	20	13	9	9	40	3330	
BK35	35	50	14	67	12	140	96	70	52	88	79	35	114	26	12	11	14	20	13	12	12	50	4380	
BK40	40	61	18	76	15	160	110	80	60	100	90	37	130	33	14	14	18	26	17.5	15	15	50	6670	

## BF Series

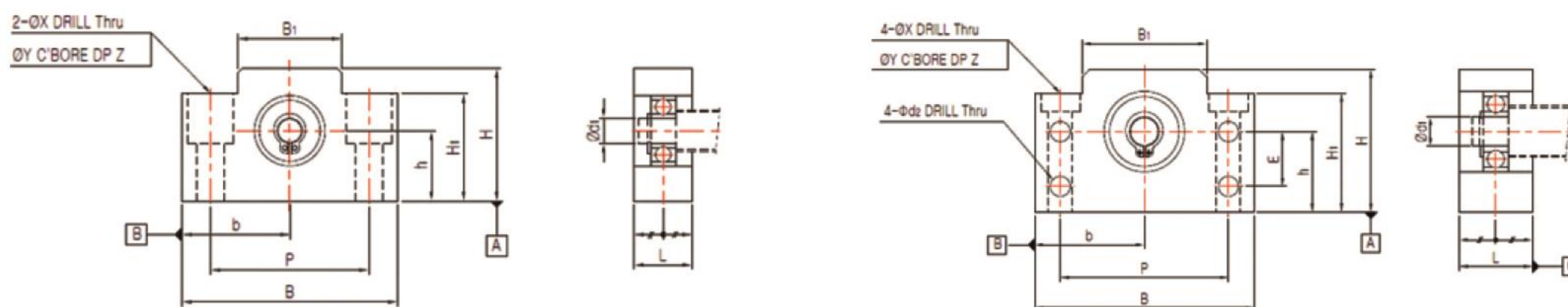

BF 10~40

Model	d <sub>1</sub>	L	B	H	b±0.02	h±0.02	B <sub>1</sub>	H <sub>1</sub>	E	P	d <sub>2</sub>	X	Y	Z	Mess (g)	Bearing	Snap Ring
BF6/8	6	14	52	32	26	17	25	26	-	38	-	6.6	11	12	120	606ZZ	C6
BF10	8	20	60	39	30	22	34	32.5	15	46	5.5	6.6	10.8	5	260	608ZZ	C8
BF12	10	20	60	43	30	25	34	35	18	46	5.5	6.6	10.8	6.5	270	6000ZZ	C10
BF15	15	20	70	48	35	28	40	38	18	54	5.5	6.6	10.8	6.5	310	6002ZZ	C15
BF17	17	23	86	64	43	39	50	55	28	68	6.6	9	14	8.5	680	6203ZZ	C17
BF20	20	26	88	60	44	34	52	50	22	70	6.6	9	14	8.8	710	6004ZZ	C20
BF25	25	30	106	80	53	48	64	70	33	85	9	11	17.5	11	1340	6205ZZ	C25
BF30	30	32	128	89	64	51	76	78	33	102	11	14	20	13	1880	6206ZZ	C30
BF35	35	32	140	96	70	52	88	79	35	114	11	14	20	13	2080	6207ZZ	C35
BF40	40	37	160	110	80	60	100	90	37	130	14	18	26	17.5	3100	6208ZZ	C40



### FK Series

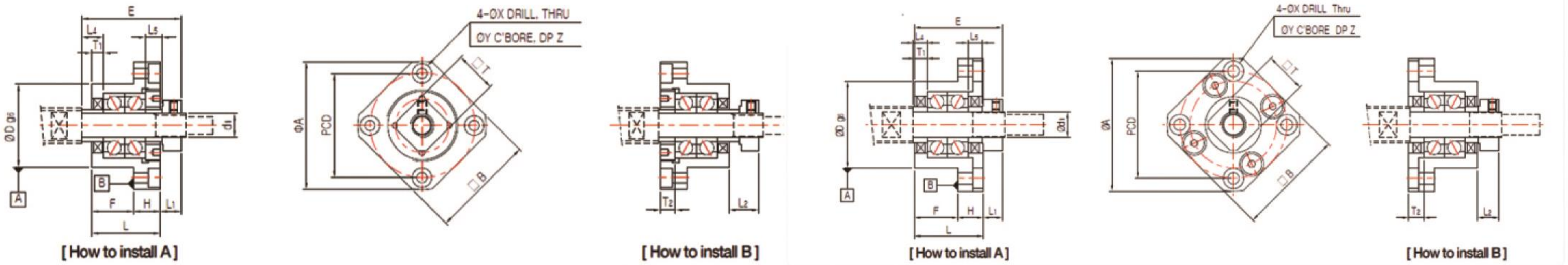

#### FK 4~8

#### FK 10~30

Model No.	d <sub>1</sub>	L	H	F	E	D	PCD	□B	How to install A		How to install B		X	Y	Z	Collar Size		□T	Mess(g)
									L <sub>1</sub>	T <sub>1</sub>	L <sub>2</sub>	T <sub>2</sub>				L <sub>4</sub>	L <sub>5</sub>		
FK4	4	15	6	9	22	18	24	25	5.5	2	6.5	3	3.4	6	4	3.5	3.5	10	40
FK5	5	16.5	6	10.5	24	20	26	26	6.5	3.5	6	3	3.4	6.5	4	4.5	4.5	11	50
FK6	6	20	7	13	29	22	28	28	5.5	3.5	8.5	4.5	3.4	6.5	4	7	5	12	65
FK8	8	23	9	14	33.5	28	35	35	7	4	10	5	3.4	6.5	4	7.5	5.5	14	125
FK10	10	27	10	17	29.5	34	42	42	7.5	5	8.5	6	4.5	8	4	5.5	5.5	16	200
FK12	12	27	10	17	29.5	36	44	44	7.5	5	8.5	6	4.5	8	4	5.5	5.5	19	225
FK15	15	32	15	17	36	40	50	52	10	6	12	8	5.5	9.5	6	10	10	22	340
FK17	17	45	22	23	46	50	62	61	10	9	13	12	6.6	11	10	9	9	24	770
FK20	20	52	22	30	50	57	70	68	8	10	12	14	6.6	11	10	11	11	30	1065
FK25	25	57	27	30	60	63	80	79	13	10	20	17	9	15	13	15	15	35	1465
FK30	30	62	30	32	61	75	95	93	11	12	17	18	11	17.5	15	9	9	40	2300

### FF Series

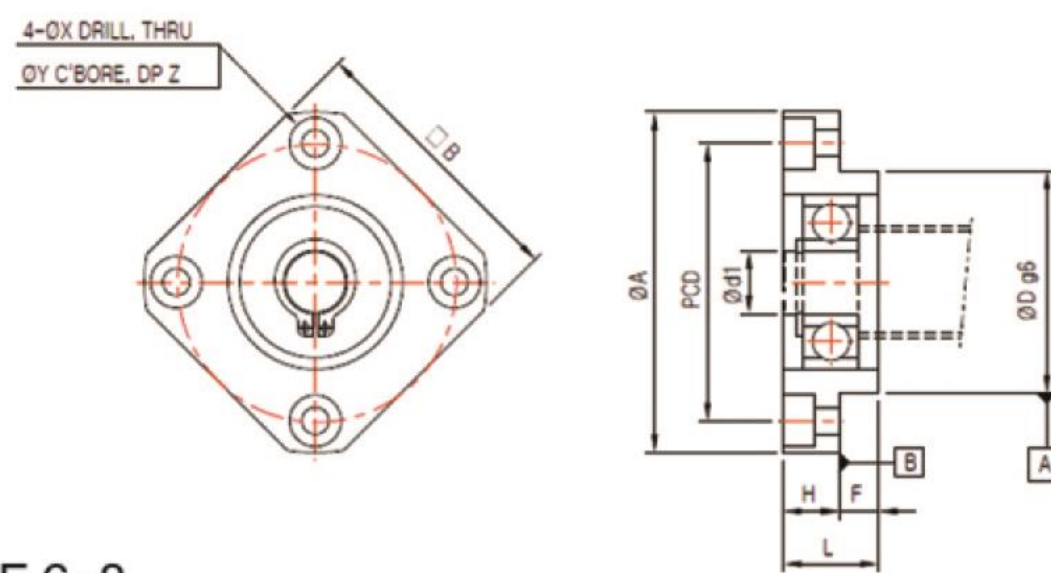

#### FF 6~8

Model	d <sub>1</sub>	L	H	F	D	A	PCD	B	X	Y	Z	Mess (g)	Bearing	Snap Ring
FF6-8	6	10	6	4	22	36	28	28	3.4	6.5	3	30	606ZZ	C6
FF10	8	12	7	5	28	43	35	35	3.4	6.5	4	60	608ZZ	C8
FF12	10	15	7	8	34	52	42	42	4.5	8	4	100	6000ZZ	C10
FF15	15	17	9	8	40	63	50	52	5.5	9.5	5.5	140	6002ZZ	C15
FF17	17	20	11	9	50	77	62	61	6.5	11	6.5	290	6203ZZ	C17
FF20	20	20	11	9	57	85	70	68	6.6	11	6.5	380	6204ZZ	C20
FF25	25	24	14	10	63	95	80	79	9	14	8.5	590	6205ZZ	C25
FF30	30	27	18	9	75	117	95	93	11	17.5	11	930	6206ZZ	C30

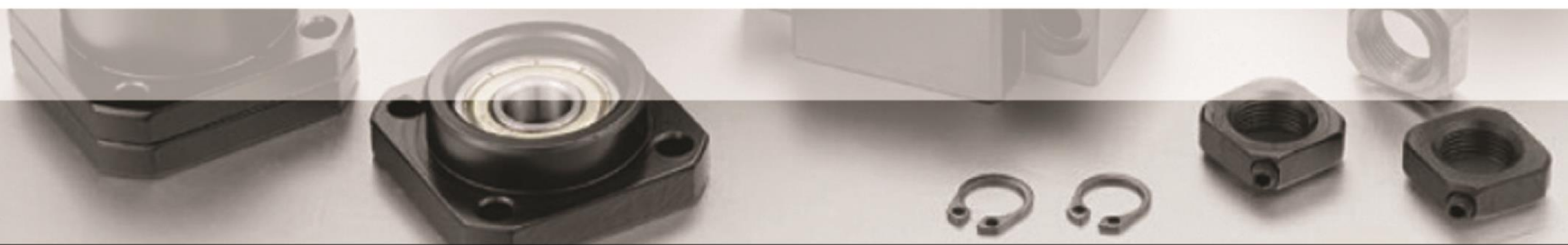



# Cable Carrier ▶



Product Code.	Dimension				Bending Radius R	Pitch	Weight Kg
	A	B	C	D			
CK15 A 015 R025	15	15	20	23	25	25	0.23
CK15 F 020 R035	15	20	20	29	35	25	0.27
CK15 F 030 R035	15	30	20	39	35	25	0.30



Product Code.	Dimension				Bending Radius R	Pitch	Weight Kg
	A	B	C	D			
CK24 A 025 R	24	25	32	39	40, 75, 100	43.5	0.45
CK24 A 040 R	24	40	32	54		43.5	0.50
CK24 A 050 R	24	50	32	64		43.5	0.55
CK24 A 060 R	24	60	32	74		43.5	0.60



Product Code.	Dimension				Bending Radius R	Pitch	Weight Kg
	A	B	C	D			
CK20 A 025 R040	20	25	26	37	40	33	0.40
CK24 B 060 R040	24	60	32	74	40	43.5	0.60



Product Code.	Dimension				Bending Radius R	Pitch	Weight Kg
	A	B	C	D			
CK25 A 040 R	25	40	42	62	40, 75, 100, 125	42	1.26
CK25 A 050 R	25	50	42	72		42	1.36
CK25 A 060 R	25	60	42	82		42	1.46
CK25 A 080 R	25	80	42	102		42	1.65
CK25 A 100 R	25	100	42	122		42	1.86



Product Code.	Dimension				Bending Radius R	Pitch	Weight Kg
	A	B	C	D			
CK20 Y 025 R040	20	25	26	37	40	33	0.40
CK20 Y 040 R040	20	40	26	52	40	33	0.45
CK20 Y 050 R040	20	50	26	62	40	33	0.50
CK20 Y 060 R040	20	60	26	72	40	33	0.55



Product Code.	Dimension				Bending Radius R	Pitch	Weight Kg
	A	B	C	D			
CK30 A 040 R	30	40	47	62	50, 75, 100, 150	52	1.36
CK30 A 050 R	30	50	47	72		52	1.46
CK30 A 060 R	30	60	47	82		52	1.56
CK30 A 080 R	30	80	47	102		52	1.47
CK30 A 100 R	30	100	47	122		52	1.84





Product Code.	Dimension				Bending Radius R	Pitch	Weight Kg
	A	B	C	D			
CK35 A 040 R	35	40	52	64	50, 75, 100, 150	56	1.45
CK35 A 050 R	35	50	52	74		56	1.53
CK35 A 060 R	35	60	52	84		56	1.61
CK35 A 080 R	35	80	52	104		56	1.76
CK35 A 100 R	35	100	52	124		56	1.91
CK35 A 120 R	35	120	52	144		56	2.06
CK35 A 125 R	35	125	52	149		56	2.13



Product Code.	Dimension				Bending Radius R	Pitch	Weight Kg
	A	B	C	D			
CK40 A 080 R	40	80	62	108	75, 100, 125, 150, 200, 250, 300	72	2.85
CK40 A 100 R	40	100	62	128		72	2.99
CK40 A 120 R	40	120	62	148		72	3.11
CK40 A 140 R	40	140	62	168		72	3.24
CK40 A 160 R	40	160	62	188		72	3.37
CK40 A 180 R	40	180	62	208		72	3.50
CK40 A 200 R	40	200	62	228		72	3.63
CK40 A 100 R	40	100	62	128		72	3.17
CK40 A 100 R	40	100	62	128		72	3.24



Product Code.	Dimension				Bending Radius R	Pitch	Weight Kg	
	A	B	C	D				
CK35 Y 040 R	35	40	52	64	100, 150	56	1.56	
CK35 Y 060 R	35	60	52	84		56	1.66	
CK35 Y 080 R	35	80	52	104		56	1.76	
CK35 Y 100 R	35	100	52	124		56	1.86	
CK35 Y 125 R	35	125	52	149		56	2.00	
CK35 K 040 R	35	40	52	64		100, 150	56	1.68
CK35 K 060 R	35	60	52	84			56	1.78
CK35 K 080 R	35	80	52	104			56	1.88
CK35 K 100 R	35	100	52	124	56		2.15	
CK35 K 125 R	35	125	52	149	56		2.35	



Product Code.	Dimension				Bending Radius R	Pitch	Weight Kg	
	A	B	C	D				
CK60 A 080 R	60	80	82	112	100, 150, 200, 250, 300	91	2.98	
CK60 A 100 R	60	100	82	132		91	3.11	
CK60 A 120 R	60	120	82	152		91	3.24	
CK60 A 140 R	60	140	82	172		91	3.37	
CK60 A 160 R	60	160	82	192		91	3.50	
CK60 A 180 R	60	180	82	212		91	3.63	
CK60 A 200 R	60	200	82	232		91	3.76	



Product Code.	Dimension				Bending Radius R	Pitch	Weight Kg	
	A	B	C	D				
CK42 A 040 R	42	40	58	67	75, 100, 150, 200	62	1.68	
CK42 A 050 R	42	50	58	77		62	1.74	
CK42 A 060 R	42	60	58	87		62	1.80	
CK42 A 080 R	42	80	58	107		62	1.93	
CK42 A 100 R	42	100	58	127		62	2.06	
CK42 A 120 R	42	120	58	147		62	2.20	
CK42 A 125 R	42	125	58	152		62	2.28	
CK42 Y 050 R	42	50	58	77		100, 150, 200	62	1.90
CK42 Y 080 R	42	80	58	107	62		2.02	
CK42 Y 100 R	42	100	58	127	62		2.14	
CK42 Y 125 R	42	125	58	152	62		2.26	
CK42 K 050 R	42	50	58	77	62		2.36	
CK42 K 080 R	42	80	58	107	62		2.48	
CK42 K 100 R	42	100	58	127	62		2.60	
CK42 K 125 R	42	125	58	152	62		2.72	



Product Code.	Dimension				Bending Radius R	Pitch	Weight Kg	
	A	B	C	D				
CK60 Y 080 R	60	100	82	132	150, 200, 250, 300	91	3.00	
CK60 Y 140 R	60	140	82	172		91	3.40	
CK60 Y 200 R	60	200	82	232		91	3.90	
CK60 K 080 R	60	100	82	132		91	3.50	
CK60 K 140 R	60	140	82	172		91	3.90	
CK60 K 200 R	60	200	82	232		91	4.40	





## پاور لاک

- ساختار بسیار مقاوم
- راحتی نصب
- حذف جای خار از روی شفت



## پکیج BMS - محور حرکتی خطی

- در کورس و ابعاد مختلف
- قابل استفاده در انواع محور های عمودی و افقی
- ساخت کشور تایوان



## مهروه بالسکرو Gten

- کارایی و برگشت پذیری بالا
- عمر قابل انتظار پیش بینی شده
- گشتاور راه اندازی پایین و حرکت بی صدا
- کاربرد در ماشین آلات CNC و ابزار دقیق



## کنترلرهای Match 3

- پشتیبانی کامل از تمام نسخه های Mach3
- پشتیبانی کامل از جداسازی یا نصب USB بدون خاموش کردن دستگاه، کارت هر لحظه وضعیت اتصال USB را زیر نظر دارد.
- پشتیبانی تا حداکثر ۶ محور
- فرکانس پالس گام به گام ۴۰۰KHz است.
- دیو دسپاع کننده نور ۲ شاخص وضعیت می تواند در نشان دادن اتصال USB و با چشم کردن برای نشان دادن وضعیت کارکردن، مفید واقع شود.
- ۱۶ ورودی همه منظوره
- دارای کارکرد سرعت است، سرعت واقعی موتور چرخان ۴ رابط Mach3 در صفحه نمایش بلادرنگ
- تفکیک کننده کلیه پورت ورودی/ خروجی، تداخل، عملکرد پایدار



## اسپیندل موتورهای HQ (water cooled)

- دارای بلبرینگ های سرامیکی
- در رنج ۱.۵ کیلو وات الی ۵.۵ کیلو وات
- مخصوص عملیات فرزکاری روی فلز، چوب، سنگ، شیشه
- ایجاد صدای پایین
- ساخت کشور چین

## گیربکس Liming

- گیربکس های خورشیدی و حلزونی با دقت بالا
- دارای لقی بسیار پایین
- ساخت کشور تایوان

## پروفیل آلومینیومی

- مناسب جهت ساخت شاسی و کاور ماشین آلات صنعتی و CNC
- در سایز و ابعاد مختلف

## کنترلر DSP برند RICHAUTO

- قابلیت اتصال به ربات ها و دستگاه های CNC محور (۳ و ۴ محور)
- بدون نیاز به کامپیوتر
- قابلیت اتصال به USB
- راه اندازی SERVO MOTOR و STEPPER MOTOR
- کاربری در محیط های صنعتی
- مناسب برای دستگاه های حکاکی و برش



### PLC دلتا

- ظرفیت برنامه نویسی تا ۶۴ K
- پشتیبانی از ورودی MPG
- پشتیبانی از G-code و M-code
- دارای ۴ تا ۵۱۲ ورودی/خروجی



### سرو موتور دلتا سری A2 و B2

- در رنج ۰.۲ تا ۷.۵ کیلو وات
- انکودر با دقت ۱۷ و ۲۰ بیت
- دارای نرم افزار اقتصادی
- با قابلیت کنترل ۲ مد به صورت هم زمان
- دارای ۶۴ حافظه داخلی جهت کنترل موقعیت داخلی

### HMI دلتا

- پشتیبانی از کارت SD
- در سایز های ۴ تا ۱۰ اینچ
- موجود در رزولیشن های بالا و پایین



### اینورتر دلتا سری های تکفاز : EL , M , B , C200 , LS600 , L سری های سه فاز : M , B , C200 , C2000 , CP2000

- حداکثر فرکانس ۶۰۰ هرتز
- دارای PLC داخلی
- پشتیبانی از چند شبکه

### بلبرینگ استیل

- ساخته شده از آلیاژ کرم دار پر کربن
- مقاوم در برابر آب و رطوبت



### بلبرینگ های نسوز

- از جنس فولاد با آلیاژ مخصوص ترکیب شده با پرسلین
- سختی بسیار بالا
- مقاوم در برابر حرارت تا ۵۰۰ درجه سانتی گراد
- مقاوم در برابر زنگ زدگی
- ساخت کشور ایتالیا

### بلبرینگ مخصوص اسپیندل

- قابلیت کار در سرعت بالا
- بسیار سبک و مقاوم
- عایق الکتریکی



### پایه لرزه گیر دستگاه



### قطعات اسپیندل

- قطعات یدکی اسپیندل شامل:
- فن -درب روی اسپیندل - قاب فن - جا بلبرینگ



### دنده شانه ای

- در دو مدل صاف و مورب دقیق
- دقت بالا و صدای کم
- در رنج های ۱ الی ۱۰
- ساخت کشور تایوان

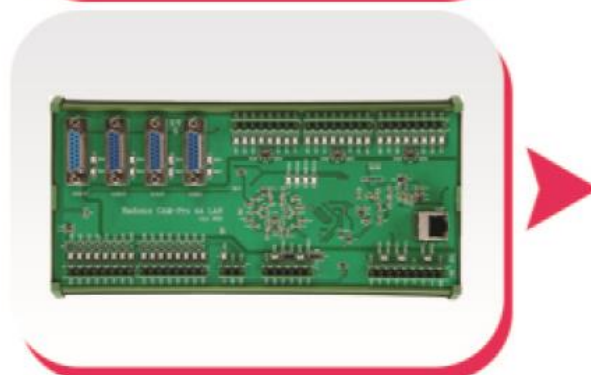

### انواع فشنگی و مهره و ISO30 برند LHC

- انواع فشنگی و مهره
- در سایز و ابعاد مختلف



### اسپیندل HSD

- در رنج توان های ۱ کیلو وات الی ۳۰ کیلو وات
- در دو مدل تعویض ابزار دستی و اتوماتیک
- ساخت کشور ایتالیا



### کنترلر ADtech

- پشتیبانی از G-CODE و مناسب برای پروسه های Motion Control
- پشتیبانی از پروتکل PMC Modbus
- تکنولوژی کنترل REAL TIME
- قابلیت کنترل تا ۶ محور سروو موتور یا استپر موتور
- قابلیت اتصال چندین کارت با کابل LAN و هاب اترنت

### کنترلر Radonix

- نرخ خروجی تا ۵۰۰۰۰۰ پالس بر ثانیه
- کنترل شش محور همزمان
- ۳۲ ورودی و ۳۲ خروجی دیجیتال
- ۲ خروجی آنالوگ و PWM
- دارای ساعت داخلی، ۲۴ قفل زماندار
- قابلیت نصب ریموت بی سیم، و هندویل
- در مدل های ۳، ۴ و ۶ محور
- پورت LAN تا فاصله ۴۰ متر از کامپیوتر

### پولی تایمینگ

- در تیپ های مختلف شامل:
- XL , L , H , ۳M , ۵M , ۸M , T۵ , T۱۰ , B-H , B-L
- در عرض های مختلف

Other product ▶