



3DM3722

Digital Stepper Drive

Manual



Contents

1. Overview	- 4 -
2. Features	- 4 -
3. Ports Introduction	- 5 -
3.1 Control Signal Input Ports.....	- 5 -
3.2 Power Interface Ports.....	- 7 -
4. Technological Index	- 8 -
5. Connections to Control Signal	- 9 -
5.1 Connections to Common Anode.....	- 9 -
5.2 Connections to Common Cathode.....	- 10 -
5.3 Connections to Differential Signal.....	- 10 -
5.4 Connections to 232 Serial Communication Interface.....	- 12 -
5.5 Sequence Chart of Control Signals.....	- 12 -
6. DIP Switch Setting	- 13 -
6.1 DP-1 Current Setting.....	- 13 -
6.2 DP-2 Micro steps Setting.....	- 14 -
6.3 Function Setting.....	- 14 -
7. Faults alarm and LED flicker frequency	- 15 -
8. Appearance and Installation Dimensions	- 17 -
9. Typical Connection	- 17 -
10. Parameter Setting	- 19 -
11. Processing Methods to Common Problems and Faults	- 24 -
11.1 Power on power light off.....	- 24 -
11.2 Power on red alarm light on.....	- 24 -
11.3 After input pulse signal but the motor not running.....	- 24 -

1. Overview

The 3DM3722 is a three phase digital stepper driver based on DSP. Its Micro step resolutions and output current are programmable. And it has advanced control algorithm, which can bring a unique level of system smoothness, provides optimum torque and mid-range instability. The control algorithm of Multi-Stepping can make stepper motor has smooth system performance. The control algorithm of torque compensation can improve the torque of motor in the high speed. The control algorithm of motor self-test and parameter auto-setup technology offers optimum responses with different motors and easy-to-use. The control algorithm of smoothness can enhance the acceleration and deceleration of motor. Its unique features make the 3DM3722 to be an ideal solution for applications.

2. Features

- ◆ Parameter auto-setup and motor self-test
- ◆ Multi-Stepping inside
- ◆ Small noise, low heating, smooth movement
- ◆ Torque compensation in high speed
- ◆ Variable current control technology, High current efficiency
- ◆ Accelerate and decelerate control inside, Great improvement in smoothness of starting or stopping the motor

- ◆ Support PUL/DIR and CW/CCW modes
- ◆ Storage the position of motor
- ◆ Optically isolated input and compatible with 5V or 24V
- ◆ User-defined micro steps
- ◆ Microstep resolutions and Output current programmable
- ◆ Over current, over voltage and lack phase protection
- ◆ Green light means running while red light means protection or off-line

3. Ports Introduction

3.1 Control Signal Input Ports

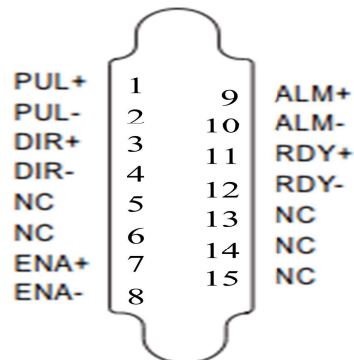

Port	Symbol	Name	Remark
1	PUL+	Pulse input +	Compatible with 5V or 24V
2	PUL-	Pulse input -	

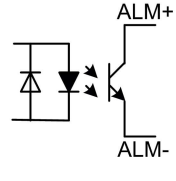
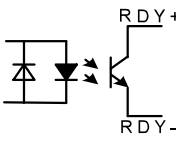
3	DIR+	Direction input -	Compatible with 5V or 24V
4	DIR-	Direction input +	
7	ENA+	Enable input +	Compatible with 5V or 24V
8	ENA-	Enable input -	
9	ALM+	Alarm Output+	
10	ALM-	Alarm Output-	
11	RDY+	Ready Output+	
12	RDY-	Ready Output-	

3.2 Power Interface Ports

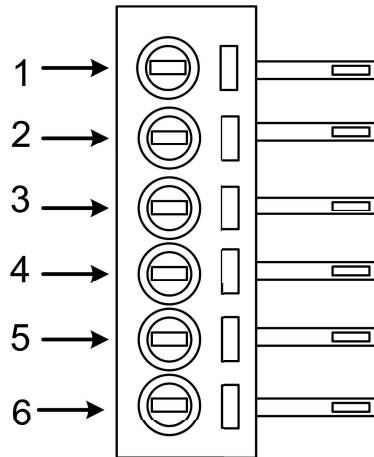

Port	Identification	Symbol	Name	Remark
1	Motor Phase Wire Input Ports	U	Phase U	Motor Phase
2		V	Phase V	
3		W	Phase W	
5	Power Input Ports	AC1	AC80V-240V	
6		AC2		
4	GND	GND	GND	

4. Technological Index

Input Voltage	80~240VAC	
Output Current	8A	
Pulse Frequency max	200K	
Communication rate	57.6Kbps	
Protection	<ul style="list-style-type: none"> ● Over current peak value 15A±10% ● Over voltage value 350V ● The over position error range can be set through the HISU 	
Overall Dimensions (mm)	200×146×80	
Weight	Approximate 1500g	
Specifications	Environment	Avoid dust, oil fog and corrosive gases
	Operating Temperature	+70°C Max
	Storage Temperature	-20°C~+80°C
	Humidity	40~90%RH
	Cooling method	Natural cooling or forced air cooling

5. Connections to Control Signal

5.1 Connections to Common Anode

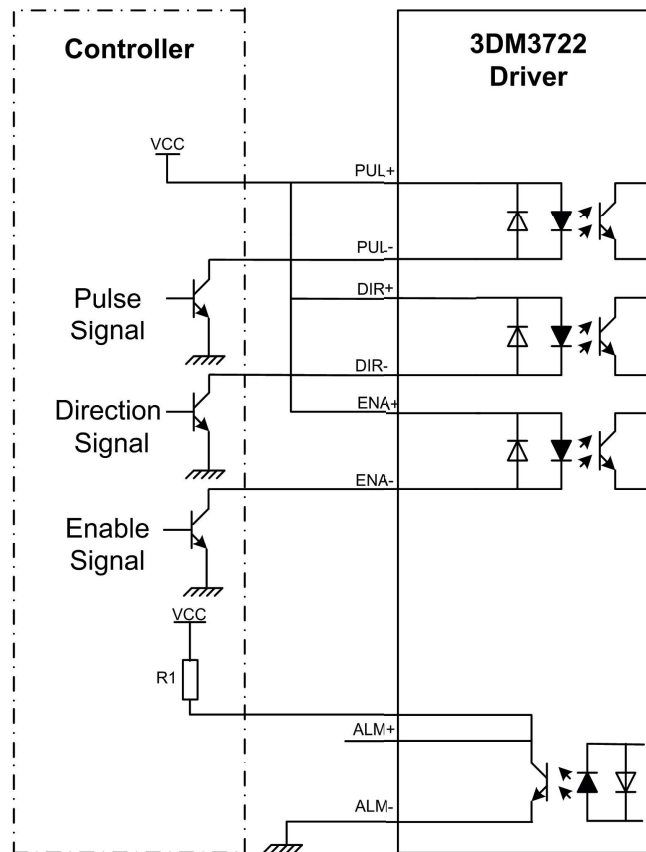

Remark:

VCC is compatible with 5V or 24V;

R(3~5K) must be connected to control signal terminal.

5.2 Connections to Common Cathode

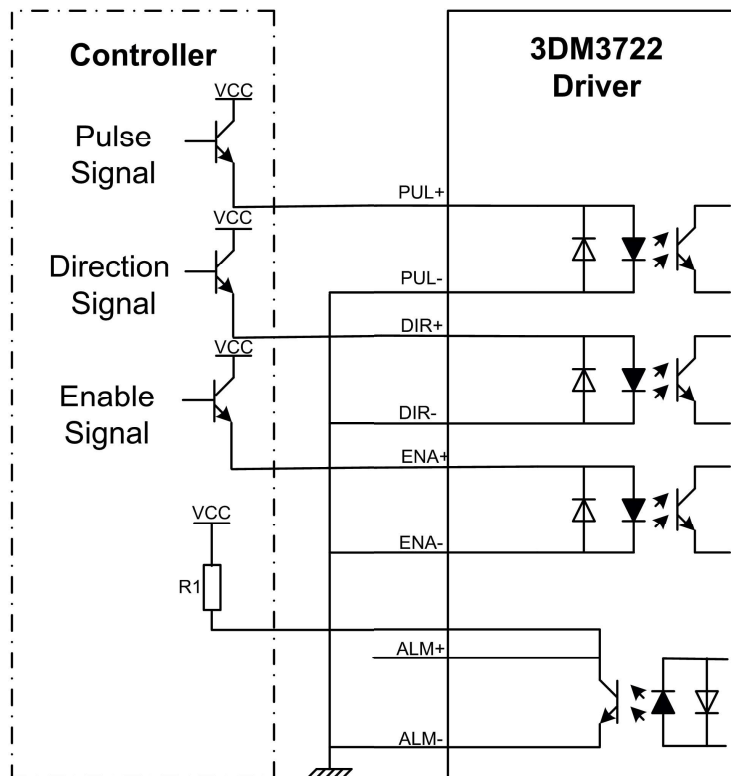

Remark:

VCC is compatible with 5V or 24V;

R(3~5K) must be connected to control signal terminal.

5.3 Connections to Differential Signal

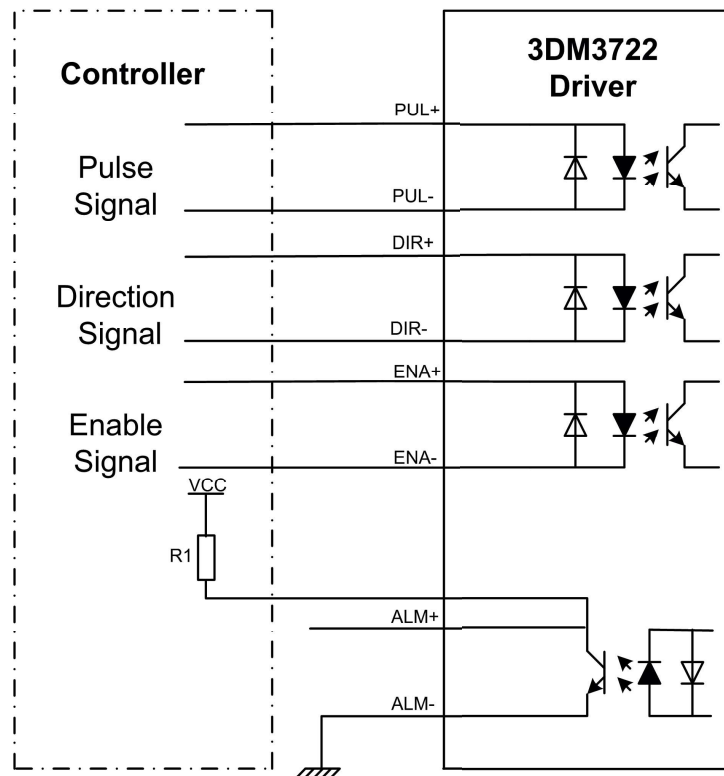

Remark:

VCC is compatible with 5V or 24V;

R(3~5K) must be connected to control signal terminal.

5.4 Connections to 232 Serial Communication Interface

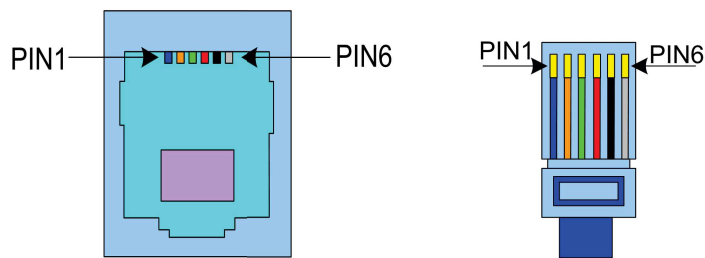

Crystal Head foot	Definition	Remark
1	TXD	Transmit Data
2	RXD	Receive Data
4	+5V	Power Supply to HISU
6	GND	Power Ground

5.5 Sequence Chart of Control Signals

In order to avoid some fault operations and deviations, PUL, DIR and ENA should abide by some rules, shown as following diagram:

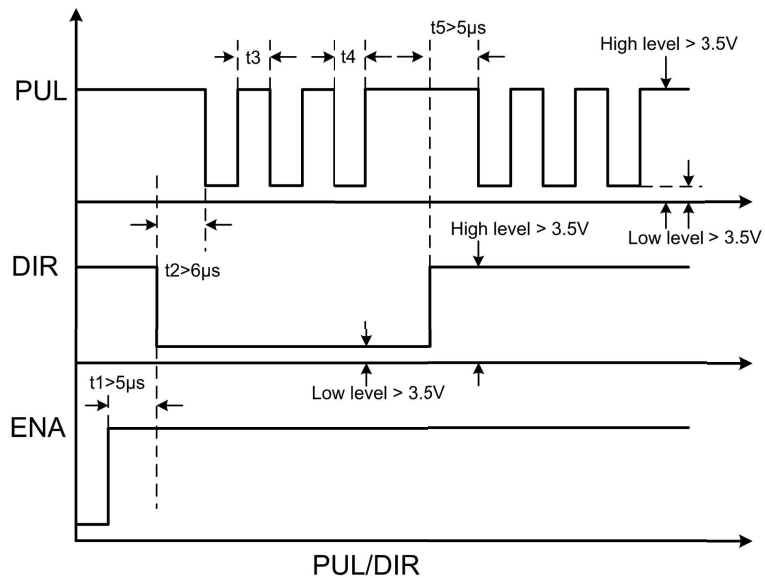

Remark:

- a. t_1 : ENA must be ahead of DIR by at least $5 \mu s$. Usually, ENA+ and ENA- are NC (not connected).
- b. t_2 : DIR must be ahead of PUL active edge by $6 \mu s$ to ensure correct direction;
- c. t_3 : Pulse width not less than $2.5 \mu s$;
- d. t_4 : Low level width not less than $2.5 \mu s$.

6. DIP Switch Setting

6.1 DP-1 Current Setting

The current setting is in the following table.

Dial switch Current	D1	D2	D3	D4
1. 2A	0	0	0	0
1. 5A	0	0	0	1
2. 0A	0	0	1	0
2. 3A	0	0	1	1
2. 5A	0	1	0	0
3. 0A	0	1	0	1
3. 2A	0	1	1	0
3. 6A	0	1	1	1
4. 0A	1	0	0	0
4. 5A	1	0	0	1
5. 0A	1	0	1	0
5. 3A	1	0	1	1
5. 8A	1	1	0	0
6. 2A	1	1	0	1
6. 5A	1	1	1	0
7. 0A	1	1	1	1

6.2 DP-2 Micro steps Setting

The micro steps setting is in the following table. And the micro steps

can be also setting through the HISU. The details can be seen in the tenth sections.

Dial switch Micro steps	D1	D2	D3	D4
400	1	1	1	1
500	1	1	1	0
600	1	1	0	1
800	1	1	0	0
1000	1	0	1	1
1200	1	0	1	0
2000	1	0	0	1
3000	1	0	0	0
4000	0	1	1	1
5000	0	1	1	0
6000	0	1	0	1
10000	0	1	0	0
12000	0	0	1	1
20000	0	0	1	0
30000	0	0	0	1
60000	0	0	0	0

6.3 Function Setting

D5 (PUL/DIR and CW/CCW modes)	ON	CW/CCW
	OFF	PUL+DIR
D6 (self run)	ON	Motor self run at 30rpm speed
	OFF	Motor run by pulse input

7. Faults alarm and LED flicker frequency

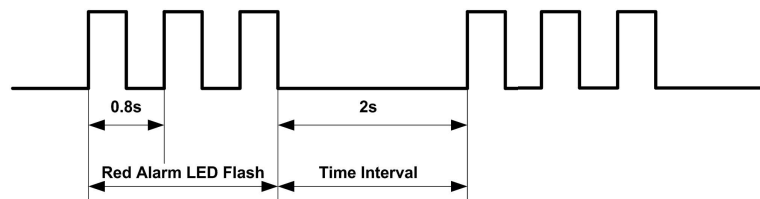

Flicker Frequency	Description to the Faults
1	Error occurs when the motor coil current exceeds the drive's current limit.
2	Voltage reference error in the drive
3	Parameters upload error in the drive
4	Error occurs when the input voltage exceeds the drive's voltage limit.
5	Lack phase of motor.

8. Appearance and Installation Dimensions

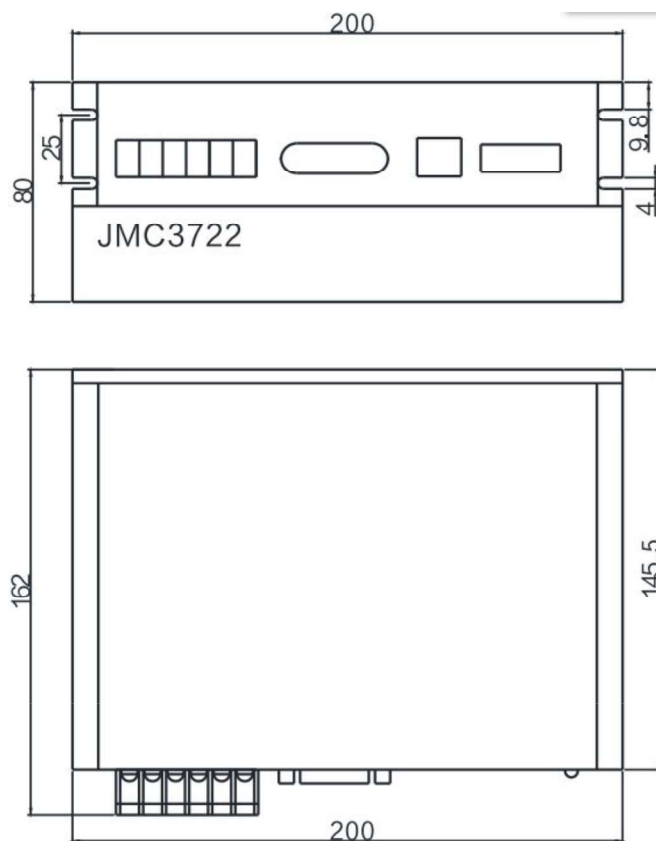

9. Typical Connection

Here is the typical connection of 3DM3722.

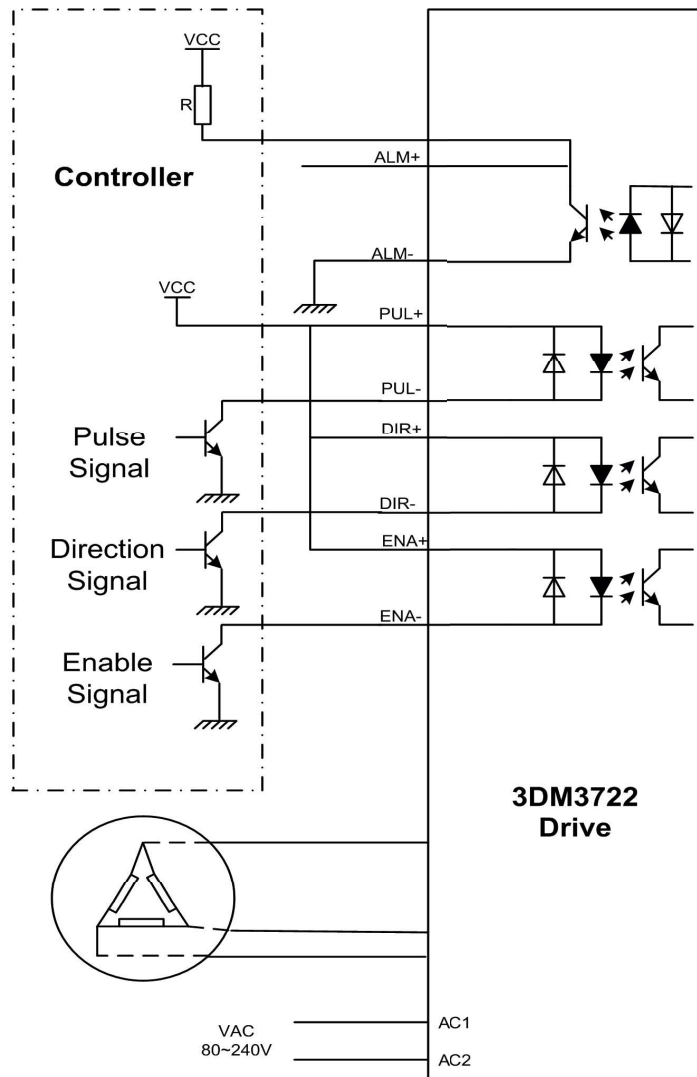

10. Parameter Setting

The parameter setting method of 3DM3722 drive is use a HISU adjuster through the 232 serial communication ports, only in this way we can set the parameters we want. There are a set of best default parameters to the corresponding motor which are carefully adjusted by our engineers, users only need refer to the following table, specific condition and set the correct parameters.

Actual value = Set value × the corresponding dimension

Mode	Definition	Range	Dimension	Drive Restart	Default Value
P1	Current loop Kp	0—4000	0.02	Y	500
P2	Current loop Ki	0—1000	0.001	Y	100
P3	Damping coefficient	0—500	1	N	200
P4	Reserved				
P5	Current of motor off-line	0—1000	1A	N	0
P6	Amplitude of resonance point	0—1000	0.001	N	10
P7	Phase of resonance point	0—1000	0.001	N	50
P8	Reserved				
P9	Reserved				
P10	Enable signal level	0—1	1	N	1
P11	Reserved				
P12	Reserved				
P13	Reserved				

P14	User-defined micro steps	4—1000	50	Y	0
P15	Time of standstill current	0—4000	0.5ms	N	1000
P16	Percentage of standstill current	0—100	0.01	Y	50
P17	Speed smoothness	0—10	1	N	5
P18	Enable of position memory	0—1	1	Y	1
P19	User-defined resistance of motor	0—100	0.1Ohm	Y	0
P20	User-defined inductance of motor	0—100	mh	Y	0
P21	Result of position memory	0—128	1		0
P22	PUL filter	0—10	1	Y	3
P23	Lack phase detect enable	0—1	1	Y	0
P24	Initial current saturation	0-10	0.1A	N	2
P25	Erasure DSP				

There are total 25 parameter configurations, use the HISU to download the configured parameters to the drive, the detail descriptions to every parameter configuration are as follows:

Item	Description
-------------	--------------------

<p>Current loop Kp Current loop Ki</p>	<p>The P1 and P2 is used to set Kp and Ki of Current loop Kp at the moment of power-on. If you set the Kp is 500, the Kp and Ki is got by the Self-tuning algorithm. But when you set the Kp is not 500, the Kp and Ki is the values which you set.</p>
<p>Damping coefficient</p>	<p>This parameter is used to change the damping coefficient in case of the desired operating state is under resonance frequency.</p>
<p>Current of motor off-line</p>	<p>This parameter is used to set the current of motor when the ENA has the input signal. 0 means the current of motor off-line is 0A.</p>
<p>Amplitude Phase</p>	<p>Amplitude and Phase is adjustment for resonance, and compensate torque in high speed.</p>
<p>Enable Control</p>	<p>This parameter is set to control the Enable input signal level, 0 means low, while 1 means high.</p>
<p>User-defined micro steps</p>	<p>This parameter is set of user-defined micro steps. The actual micro steps = the set value \times 50. For example, if the parameter is 4, the micro steps is $4 \times 50 = 800$. But If this parameter is 0, which means micro steps is set by the outer DIP switches.</p>

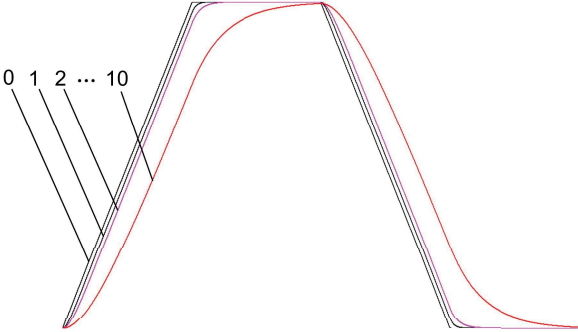
<p>Time of standstill current</p>	<p>This parameter is set the time when the standstill current is set to be half of the selected dynamic current or other current.</p>
<p>Percentage of standstill current</p>	<p>This parameter is set the percentage of standstill current.</p>
<p>Speed smoothness</p>	<p>This parameter is set to control the smoothness of the speed of the motor while acceleration or deceleration, the larger the value, the smoother the speed in acceleration or deceleration.</p> 
<p>Enable of position memory</p>	<p>This parameter is set to enable the function of position memory. 0 means disable, while 1 means enable. If set 1, the 3DM3722 can remember the position of motor in the next time of power on.</p>
<p>Command Type</p>	<p>This parameter is set to choice the PUL/DIR mode or CW/CCW mode. 0 means PUL/DIR mode,while means CW/CCW mode.</p>

User-defined resistance of motor	This parameter is set the resistance of motor. 0 means 3DM3722 gets the resistance by control algorithm of Parameter auto-setup, while 1 means 3DM3722 gets the resistance through user sets.
User-defined inductance of motor	This parameter is set the inductance of motor. 0 means 3DM3722 gets the inductance by control algorithm of Parameter auto-setup, while 1 means 3DM3722 gets the inductance through user sets.
Result of position memory	This parameter is set to control the smoothness of Display the result of position memory
PUL filter	This parameter is set the filter coefficient of PUL.
Lack phase detect enable	This parameter is to enable the function of lack phase test. 0 means enable,1 meas disable.
Initial current saturation	This parameter is to set the Initial current saturation.
Erasure DSP	If this parameter is 25,The DSP will be erased.

11. Processing Methods to Common Problems and Faults

11.1 Power on power light off

- No power input, please check the power supply circuit. The voltage is too low.

11.2 Power on red alarm light on

- Please check the motor is connected with the drive.
- The stepper digital drive is over voltage or under voltage. Please lower or increase the input voltage.

11.4 After input pulse signal but the motor not running

- Please check the input pulse signal wires are connected in reliable way.
- Please make sure the input pulse mode is corresponding with the real input mode.
- The Driver is disabled