

Linear Guideways MG Series

2-4-13 Dimensions for MGN/MGW Series

(1) MGN-C / MGN-H

MGN5

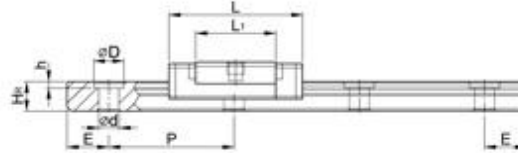
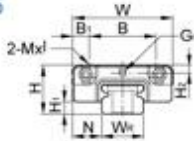

MGN7, MGN9, MGN12

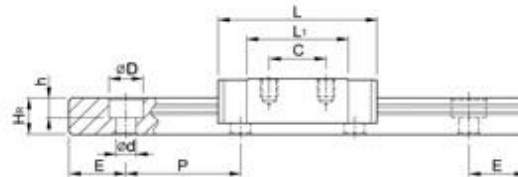
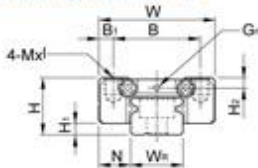

MGN15

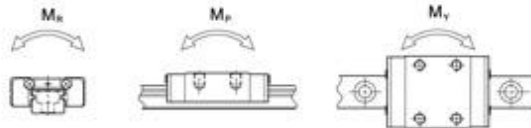
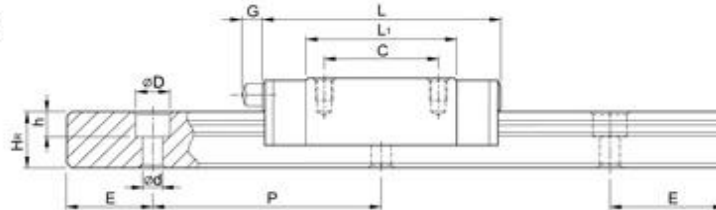
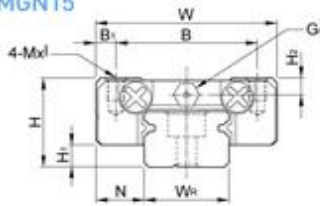

Model No.	Dimensions of Assembly (mm)		Dimensions of Block (mm)										Dimensions of Rail (mm)					Mounting Bolt for Rail (mm)	Basic Dynamic Load Rating C (kN)	Basic Static Load Rating C ₀ (kN)	Static Rated Moment			Weight				
	H	H ₁	N	W	B	B ₁	C	L ₁	L	G	G ₁	Mxl	H ₂	W _k	H _e	D	h				d	P	E	M _b	M _x	M _y	Block	Rail
	mm	mm	mm	mm	mm	mm	mm	mm	mm	mm	mm	mm	mm	mm	mm	mm	mm	mm	mm	mm	mm	N-m	N-m	N-m	kg	kg/m		
MGN5C	6	1.5	3.5	12	8	2	-	9.6	16	-	Ø0.8	M2x1.5	1	5	3.6	3.6	0.8	2.4	15	5	M2x6	0.54	0.84	2	1.3	1.3	0.008	0.15
MGN7C	8	1.5	5	17	12	2.5	8	13.5	22.5	-	Ø1.2	M2x2.5	1.5	7	4.8	4.2	2.3	2.4	15	5	M2x6	0.98	1.24	4.70	2.84	2.84	0.010	0.22
MGN7H																						1.37	1.96	7.64	4.80	4.80	0.015	
MGN9C	10	2	5.5	20	15	2.5	10	18.9	28.9	-	Ø1.4	M3x3	1.8	9	6.5	6	3.5	3.5	20	7.5	M3x8	1.86	2.55	11.76	7.35	7.35	0.016	0.38
MGN9H																						2.55	4.02	19.60	18.62	18.62	0.026	
MGN12C	13	3	7.5	27	20	3.5	15	21.7	34.7	-	Ø2	M3x3.5	2.5	12	8	6	4.5	3.5	25	10	M3x8	2.84	3.92	25.48	13.72	13.72	0.034	0.65
MGN12H																						3.72	5.88	38.22	36.26	36.26	0.054	
MGN15C	16	4	8.5	32	25	3.5	20	26.7	42.1	4.5	M3	M3x4	3	15	10	6	4.5	3.5	40	15	M3x10	4.61	5.59	45.08	21.56	21.56	0.059	1.06
MGN15H																						6.37	9.11	73.50	57.82	57.82	0.092	

Note : 1 kgf = 9.81 N

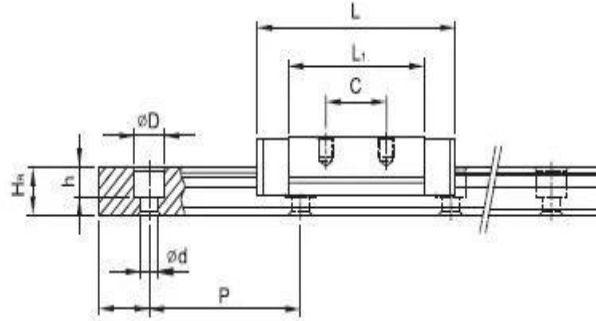
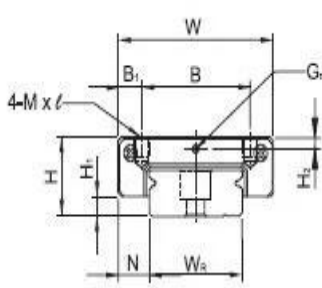

► MGW 15

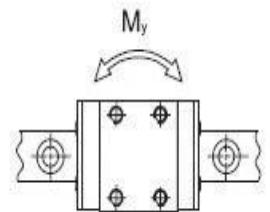
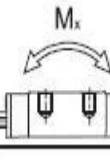
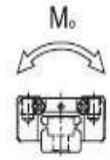
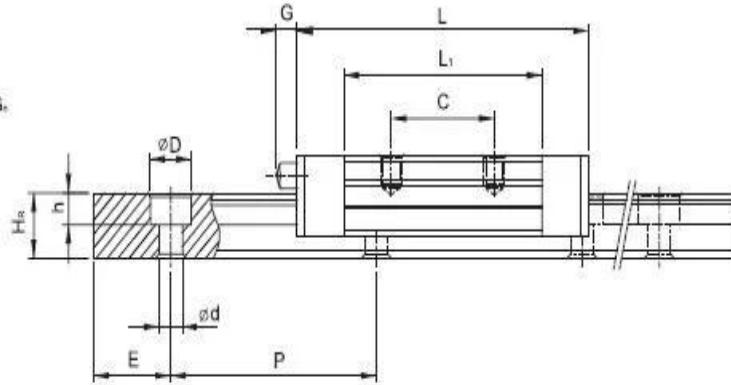
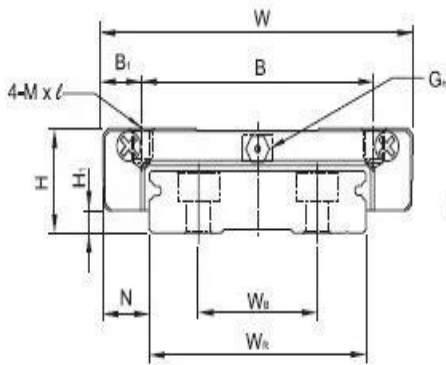

型號	組件尺寸 (mm)			滑塊尺寸 (mm)								滑軌尺寸 (mm)										滑軌的 固定螺 栓尺寸 C (mm)	基本 動額定 負荷 C (kgf)	基本 靜額定 負荷 C ₀ (kgf)	容許靜力矩			重量	
	H	H ₁	N	W	B	B ₁	C	L ₁	L	G	G _n	M x l	H ₂	W _R	W _B	H _R	D	h	d	P	E				M ₀ (kgf-m)	M _x (kgf-m)	M _y (kgf-m)	滑軌 (g)	滑塊 (kg/m)
MGW 7C MGW 7H	9	1.9	5.5	25	19	3	10	21	31.2	-	ø0.9	M3x3	1.85	14	-	5.2	6	3.2	3.5	30	10	M3x6	140	210	1.6	0.73	0.73	20	0.51
MGW 9C MGW 9H	12	2.9	6	30	21	4.5	12	27.5	39.3	-	ø1.0	M3x3	2.4	18	-	7	6	4.5	3.5	30	10	M3x8	280	420	4.09	1.93	1.93	40	0.91
MGW 12C MGW 12H	14	3.4	8	40	28	6	15	31.3	46.1	-	ø1.8	M3x3.6	2.8	24	-	8.5	8	4.5	4.5	40	15	M4x8	400	570	7.17	2.83	2.83	71	1.49
MGW 15C MGW 15H	16	3.4	9	60	45	7.5	20	38	54.8	5.2	GN3S	M4x4.2	3.2	42	23	9.5	8	4.5	4.5	40	15	M4x10	690	940	20.32	5.78	5.78	143	2.86
							35	57	73.8														910	1410	30.48	12.5	12.5	215	