

# LB 160 - 2 Stage

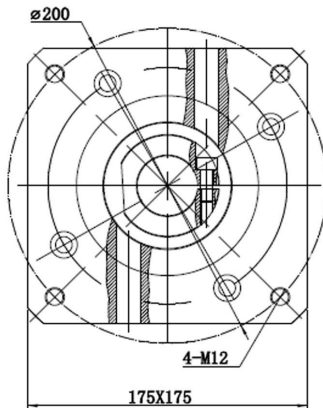
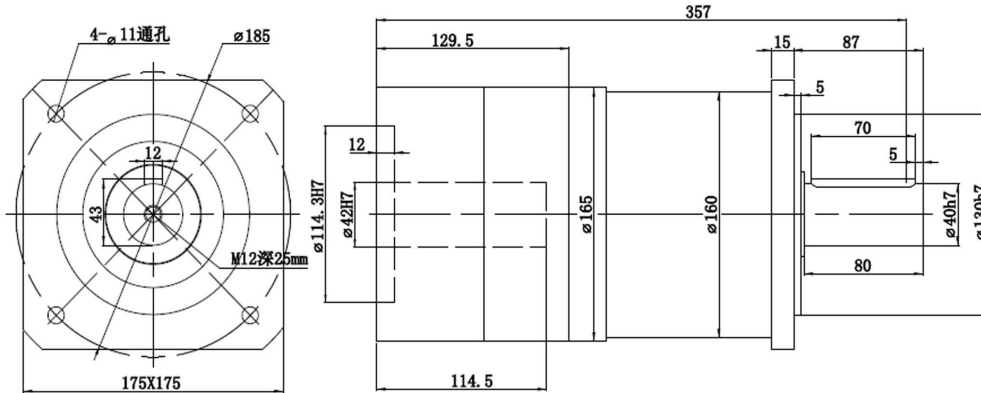

## Specification:

Gear Ratio:25:1

Rated Torque:700N.m

Instant Stop Torque:2 times of rated torque

Max Ratial Torque

Ratio	9	12	15	16	20	25	32	40	64
Torque	400	800	700	800	800	700	800	700	450